

drylin®

Lead screw technology

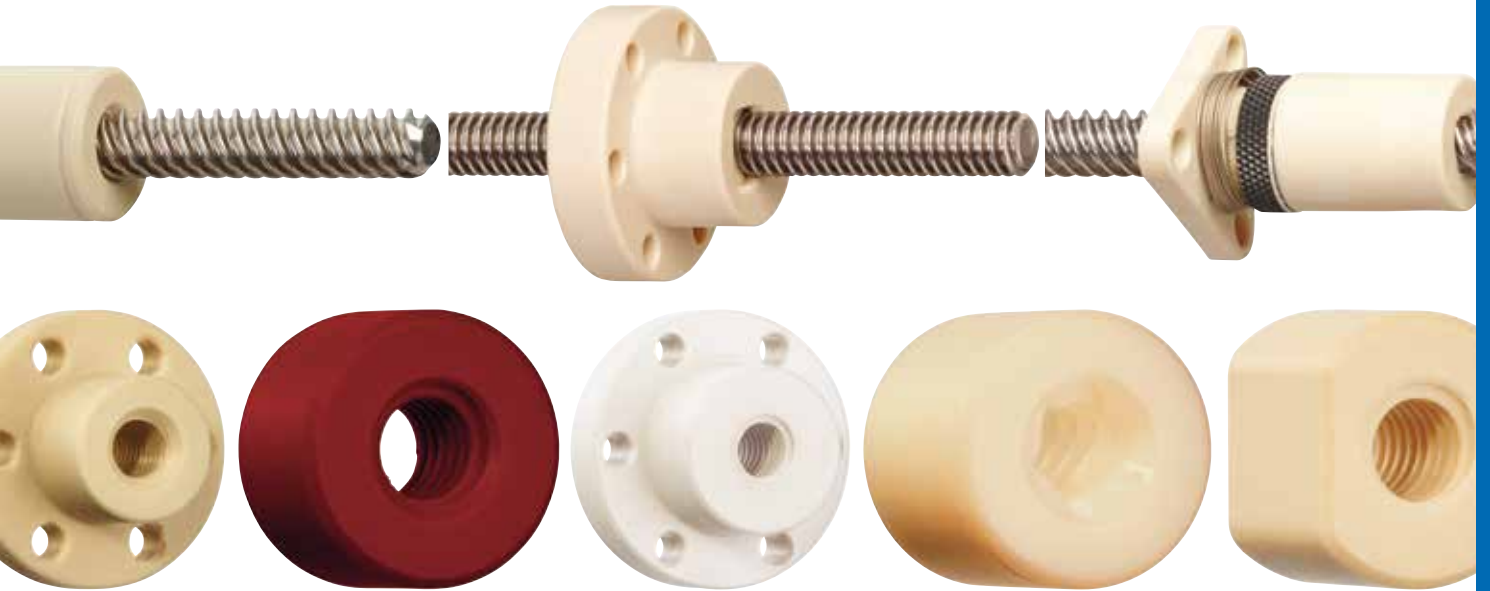

...plastics

drylin® lead screw technology – high helix thread with dryspin® technology



High helix lead screws made of stainless steel and aluminium
▶ Page 1244



High helix lead screws with right/left opposite drive
▶ Page 1248



Cylindrical lead screw nuts
▶ Page 1254



Lead screw nuts with flange
▶ Page 1260



Lead screw nuts with spanner flat, with flange
▶ Page 1264



Cost-effective injection-moulded lead screw nuts, cylindrical/with flange
▶ Page 1268



Lead screw nuts with pre-load iglidur® J
▶ Page 1277



Lead screw nuts, zero-backlash iglidur® J
▶ Page 1279

drylin® lead screw technology – trapezoidal and metric threads



Lead screws C15
▶ Page 1288

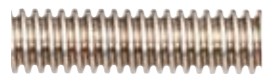

Lead screws made of stainless steel
▶ Page 1288



Lead screws made of aluminium
▶ Page 1288



Lead screws with machined end
▶ Page 1288



Multi start lead screws
▶ Page 1290



LH/RH lead screws
▶ Page 1292



Metric lead screws
▶ Page 1294



Cylindrical lead screw nuts, single start
▶ Page 1300

drylin® lead screw technology – trapezoidal and metric threads

drylin® lead screw technology – trapezoidal and metric threads



Cylindrical lead screw nuts, multi start
▶ Page 1304



Cylindrical lead screw nuts with spanner flat
▶ Page 1306



Lead screw nuts with flange, single start
▶ Page 1308



Lead screw nuts with flange, multi start
▶ Page 1310



Lead screw nuts with spanner flat, with flange
▶ Page 1312



Cylindrical lead screw nuts, lead screw nuts with flange metric
▶ Page 1314



Cost-effective injection-moulded lead screw nuts
▶ Page 1316

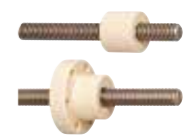

Anti-backlash lead screw nuts
▶ Page 1324

drylin® lead screw technology – trapezoidal and metric threads



Flange lead screw nuts with pre-load
▶ Page 1326

drylin® lead screw technology – special designs



Split lead screw nuts made from iglidur® J
▶ Page 1328



Lead screw nuts for linear modules
▶ Page 1330



Lead screw nuts with locating spigot
▶ Page 1334



Spherical lead screw nuts in flanged bearing housing
▶ Page 1336

drylin® lead screw technology – special designs



Spherical lead screw nuts in pillow block bearing housing
▶ Page 1337



Lead screw nuts with quick-release
▶ Page 1338



drylin® discs, made from iglidur® J
▶ Page 1339



Complete lead screw nut housing, including lead screw nut
▶ Page 1340



Lead screw support blocks with plain bearings
▶ Page 1342

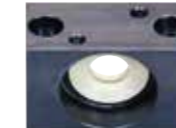

Lead screw support blocks with ball bearings
▶ Page 1346



Clamping rings
▶ Page 1348



The biggest online lead screw shop
▶ www.igus.eu/leadscrewshop

drylin® lead screw technology | Advantages

Maintenance-free, quiet operation, dirt-resistant and corrosion-resistant

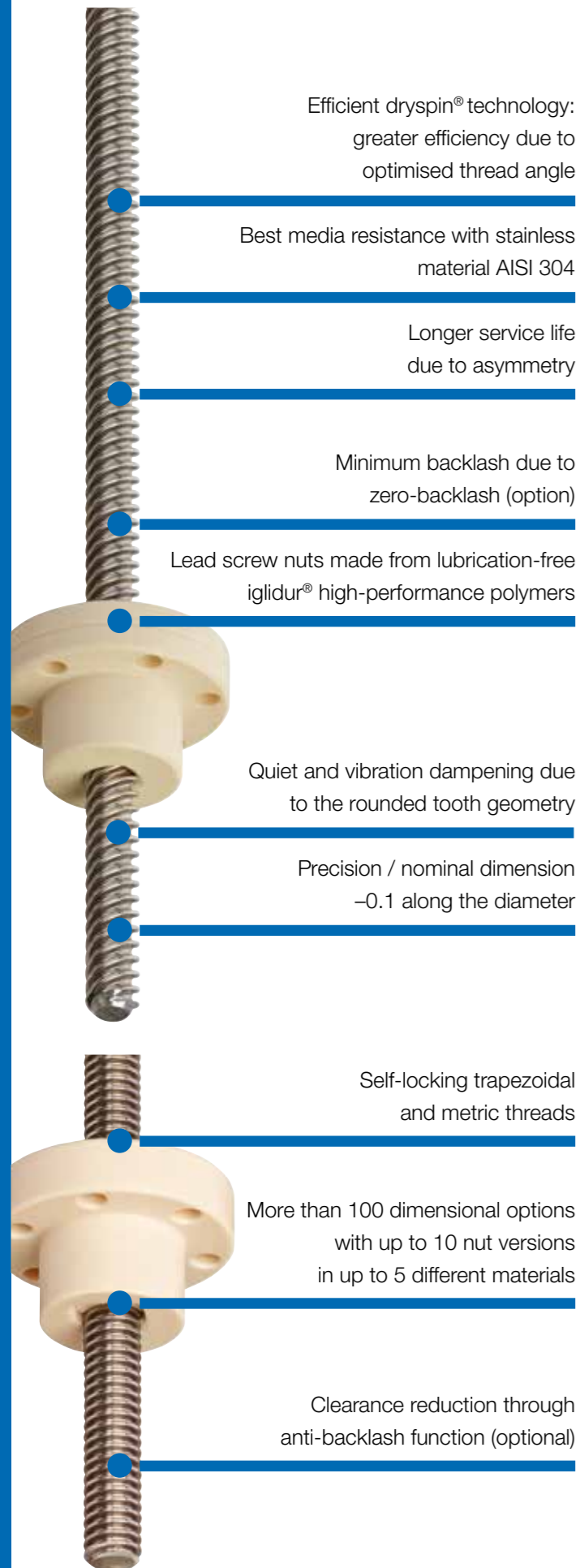

Efficient dryspin® technology:
greater efficiency due to
optimised thread angle

Best media resistance with stainless
material AISI 304

Longer service life
due to asymmetry

Minimum backlash due to
zero-backlash (option)

Lead screw nuts made from lubrication-free
igidur® high-performance polymers

Quiet and vibration dampening due
to the rounded tooth geometry

Precision / nominal dimension
-0.1 along the diameter

Self-locking trapezoidal
and metric threads

More than 100 dimensional options
with up to 10 nut versions
in up to 5 different materials

Clearance reduction through
anti-backlash function (optional)

Lubrication-free drylin® lead screw technology

Lead screw drives are machine elements that convert rotary movement into linear motion. drylin® lead screw drives are always based on self-lubricating plastic nuts, enabling long-lasting operation without external lubrication. The dryspin® technology offers a longer service life and greater efficiency for high helix threads thanks to the properties and geometries being tailored to the plastic nut and the lead screw.

- Efficient and durable dryspin® high helix threads
- Self-locking trapezoidal and metric threads
- Maintenance-free dry operation
- Silent
- Corrosion-free
- Resistant to dirt

Typical application areas

- Format adjustments
- Drive technology
- Optical equipment
- Furniture industry
- Automotive industry

 **Available from stock**
Detailed information about delivery time online.

 **Price breaks online**
No minimum order value. No minimum order quantity.

 **max. +150°C**
min. -20°C

 **Service life calculation**
► www.igus.eu/drylin-expert

 **Imperial dimensions and ACME thread (USA standard)** ► Page 1620



In accordance with EC Directive 2011/65/EU (RoHS 2)
Restriction (of the use of certain) hazardous substances

drylin® lead screw technology | Product overview

High helix threads with dryspin® technology

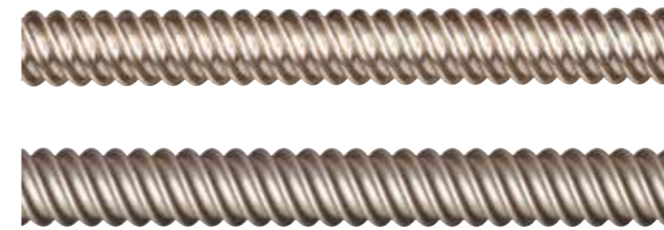

High helix lead screws

- Material: stainless steel or anodised aluminium
 - Better efficiency due to optimised thread angle
 - Quiet due to rounded tooth geometry
 - Long service life due to asymmetric dryspin® geometry
- From page 1244



High helix lead screw nuts

- Lubrication-free lead screw nuts made from 5 materials
 - Types: Cylindrical, with flange or spanner flat
 - Reduced clearance through zero-backlash
- From page 1254

Self-locking trapezoidal and metric threads

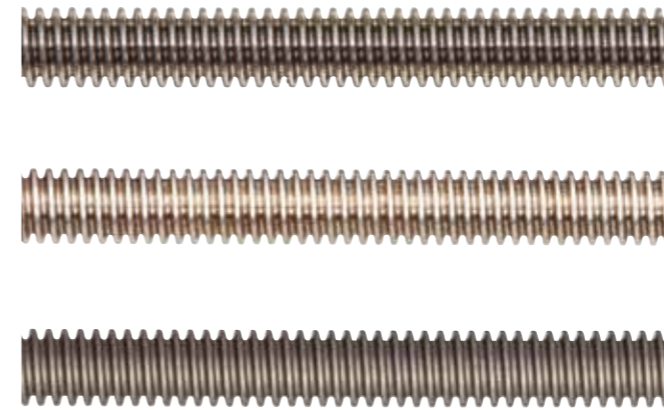

Trapezoidal and metric lead screws

- Material: steel, stainless steel or anodised aluminium
 - Product range from M3 to Tr50x8
 - Multi start lead screws and right/left opposite drive available
- From page 1288



Trapezoidal and metric lead screw nuts

- Lubrication-free lead screw nuts made from 10 different materials
 - Types: Cylindrical, with flange or spanner flat
 - Clearance reduction via anti-backlash feature
- From page 1300



Special designs

- Lead screw nuts for drylin® linear modules, with flange or locating spigot
 - Split and spherical lead screw nuts with housing
 - Disc for customised clearance adjustment
 - Fast-Forward quick release nut for fast adjustment
- From page 1327



Lead screw technology accessories

- Nut housing for drylin® lead screw nuts
 - Anodised lead screw support blocks, on plain or ball bearings
 - Clamping ring for securing lead screw
- From page 1342



This mixing station uses two drylin® trapezoidal lead screw nuts made from iglidur® high-performance polymers for the optimal mixing ratio of a two-component silicone mass.



The customer was looking for a cost-effective, lightweight and maintenance-free standard solution for small installation space. Costs and weight could be reduced thanks to the lubrication-free products from igus®.

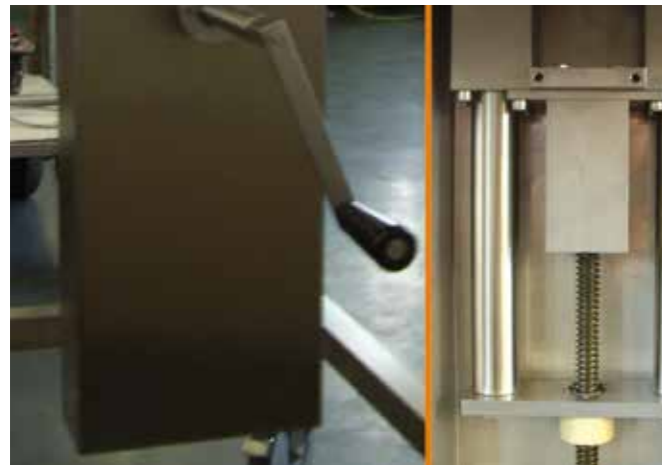

igidur® J plain bearings for shaft guides and drylin® trapezoidal lead screw nuts for the height adjustment.



Clean use of lubrication-free drylin® trapezoidal lead screw nuts in a piece of laboratory equipment for liquid handling.



drylin® lead screw drives are used for feed mechanisms. In this, the customer combines a trapezoidal lead screw nut from iglidur® W300 with a rolled trapezoidal lead screw.



All of the main components of the mechanical movements, such as the linear axis, plain bearings, guide systems, etc. use igus® products.

drylin® lead screw drive expert and configurator

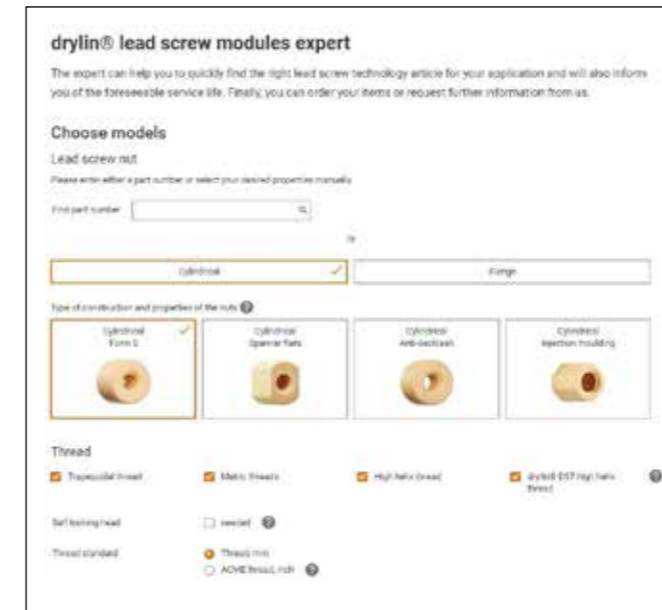

**Expert for lead screw drives:
Find and calculate suitable lead screw drives**

Our drylin® expert systems for lead screw drives help you to find the right product quickly whilst giving the predicted service life. You have the option to configure and request your required dimension for lead screw nuts and lead screws.



► www.igus.eu/leadscrew-expert



Download the online tool
app now



**Configurator for lead screw drives:
configure required dimensions**

Ask quickly and easily for lead screw nuts and lead screws in individual dimensions.



► www.igus.eu/leadscrew-configurator

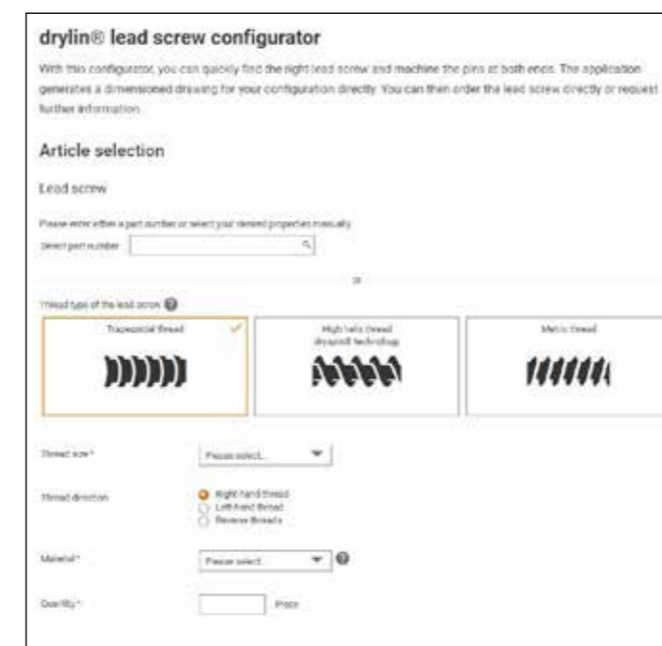

Lead screw configurator

Individually configured lead screws and machined ends can now be generated with just a few clicks. In addition to selection of the lead screw geometry and the materials, there are up to 7 options for machined ends.

► www.igus.eu/leadscrew-configurator

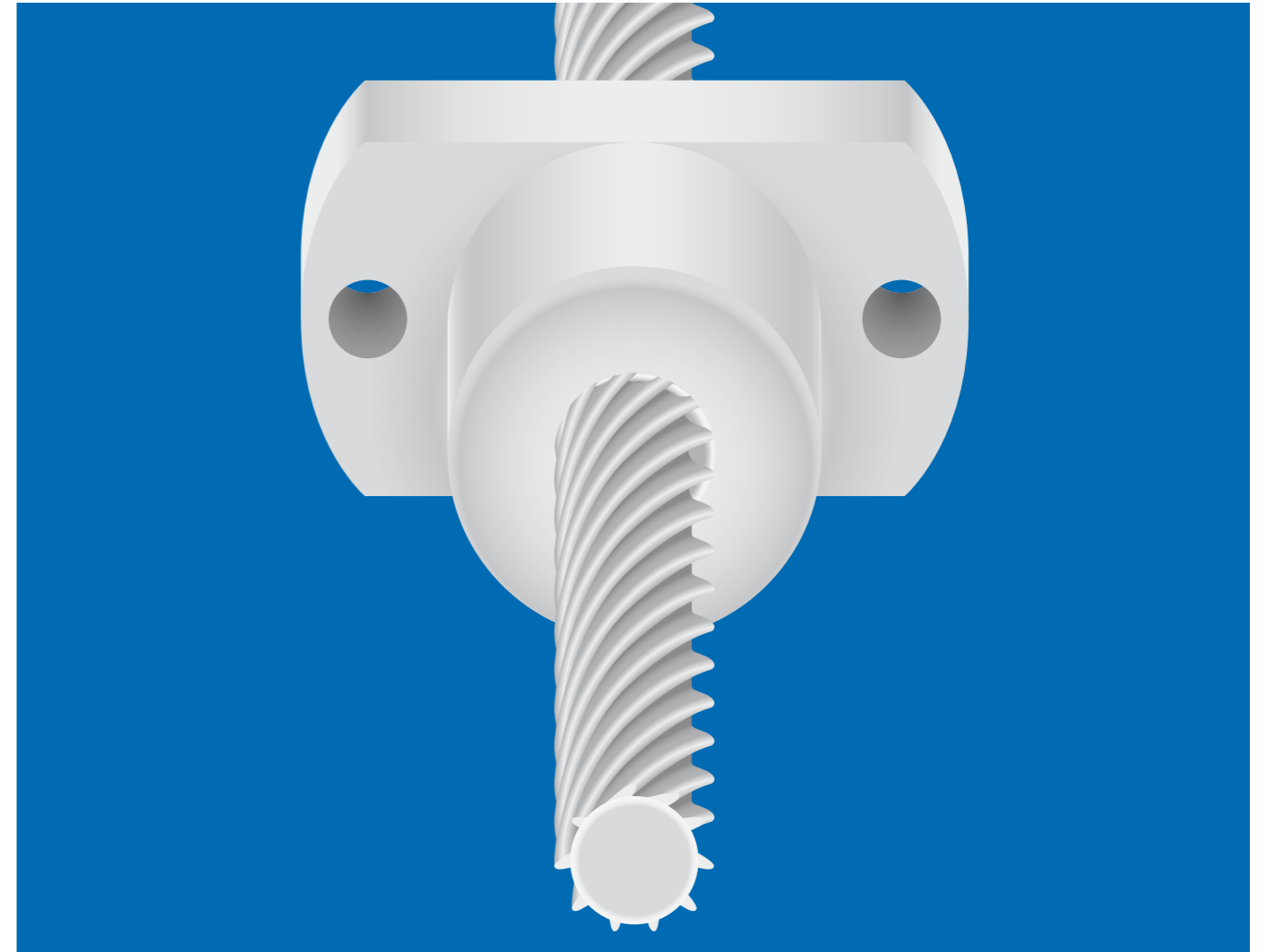

drylin® lead screw technology – dryspin® technology

Efficient high helix thread

Lead screw nuts made from lubrication-free
dry-tech® tribo-polymers

High efficiency and longer service life

Quiet operation with vibration dampening

Resistant to dirt

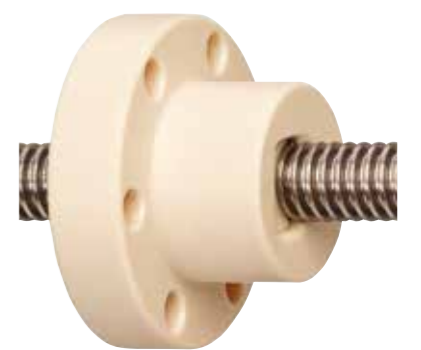

The right lead screw nut material for every technical requirement

Starting immediately, there are drylin® lead screw nuts from the full range available for every technical requirement. The full range includes lead screw nuts from 6 lubrication-free iglidur® high-performance polymers, in cylindrical design or flange variations. The ideal nut and lead screw for every application.

- Lubrication and maintenance-free
- Service life can be calculated online
- No minimum order value
- No minimum order quantity



Find and calculate suitable lead screw drives

► www.igus.eu/leadscrewdrives-finder

High efficiency at all speeds:

iglidur® J ► Page 159

- High speed
- Low wear
- Best coefficient of friction

For temperatures up to +150°C:

iglidur® J350 ► Page 204

- For high temperatures
- Good coefficient of friction with medium loads

For medium to high speeds:

iglidur® R ► Page 247

- High wear resistance for low loads
- Low moisture absorption
- Vibration-dampening

FDA-compliant for the food and pharmaceutical industry:

iglidur® A180 ► Page 401

- FDA-compliant
- For contact with food

Best running partner for hard anodised aluminium:

iglidur® J200 ► Page 261

- Low coefficient of friction and wear
- Long service life

For high speeds:

iglidur® E7 ► Page 267

- Low loads up to 200N
- Speeds up to 1,200rpm



	Unit	iglidur® J	iglidur® J350	iglidur® R	iglidur® A180	iglidur® E7	iglidur® J200
General properties							
Density	[g/cm³]	1.49	1.44	1.39	1.46	1.05	1.72
Colour		yellow	yellow	red	white	dark grey	matt grey
Max. moisture absorption at +23°C and 50% relative humidity	[% weight]	0.30	0.30	0.20	0.20	0.1	0.2
Max. total moisture absorption	[% weight]	1.30	1.60	1.10	1.30	0.1	0.7
pv value, max. (dry)	[MPa · m/s]	0.34	0.45	0.27	0.31	0.08	0.30
Mechanical properties							
Permissible surface pressure in thread at +20°C	[MPa]	4.0	3.0	2.0	3.5	0.5	2.0
Shore D hardness		74	80	77	76	61	70
Physical and thermal properties							
Max. continuous operating temperature	[°C]	+90	+150	+90	+90	+70	+90
Max. short-term operating temperature	[°C]	+120	+150	+90	+90	+70	+90
Min. continuous operating temperature	[°C]	-20	-20	-20	-20	-20	-20
Thermal conductivity	[W/m · K]	0.25	0.24	0.25	0.25	0.25	0.24
Coefficient of thermal expansion at +23°C	[K⁻¹ · 10⁻⁵]	10	7	11	11	11	8
Electrical properties							
Specific contact resistance	[Ωcm]	> 10¹³	> 10¹³	> 10¹²	> 10¹²	> 10⁹	> 10⁸
Surface resistance	[Ω]	> 10¹²	> 10¹⁰	> 10¹²	> 10¹¹	> 10⁹	> 10⁸
More material properties	Page	159	204	247	401	267	261

Higher efficiency due to optimised thread angle

Due to a flatter thread angle in dryspin® high helix lead screws (similar to a trapezoidal thread), the applied force is efficiently converted into a linear motion. Compared with a steeper thread angle, this means a lower power loss.

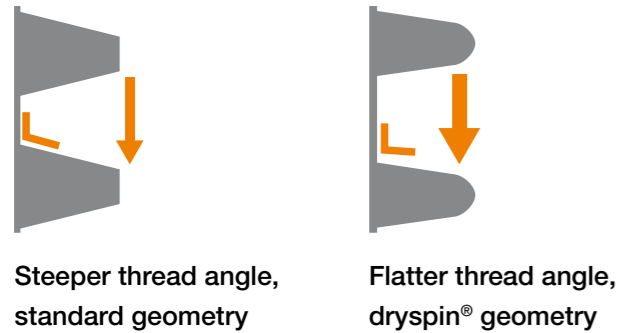

Silent and vibration-dampening due to rounded tooth geometry

Due to the rounded tooth geometry, the contact surface between the lead screw nut and the lead screw is reduced. Thereby the dryspin® lead screw nuts move without vibration, virtually noiselessly. This is because, the greater the contact of two surfaces moving against one another, the more vibrations are transmitted, which can be perceived as a rattle or squeak. The round teeth minimise this effect and the thread moves without lubrication and with no noise.

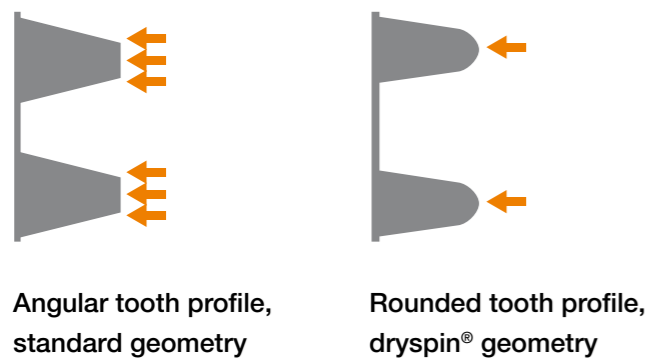

Longer service life due to asymmetry

Due to the larger distances between the individual dryspin® thread pitches, the thread ideally matches the properties of the lubrication-free igus® high-performance polymers. The proportion of the tribologically optimised polymer in the thread pitches can be extended by a factor of 1.3 for all sizes. More wear-resistant material and higher levels of efficiency are crucial for up to 5 times longer service life of standard geometries. The larger the lead screw diameter, the stronger the impact of this effect. Backlash can be minimised life-long with the use of dryspin® zero-backlash lead screw nuts with integrated spring pre-load.

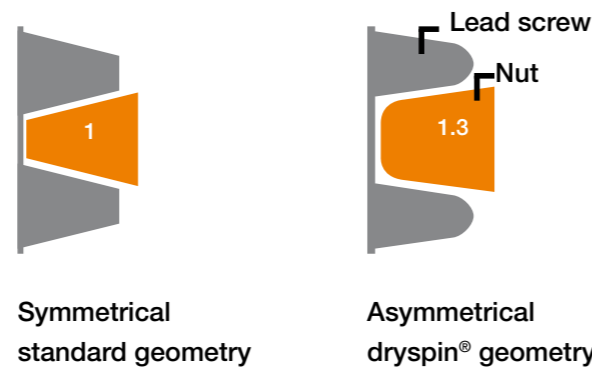

Tested: Lubrication-free iglidur® materials from igus®

Liners, sliding elements and lead screw nuts from drylin® adapted for your application: lubrication-free, tested and predictable.

- 12,000 tribology tests per year
 - More than 300 parallel test facilities
 - 140 trillion test movements
 - Continuous testing of drylin® products
- www.igus.eu/test

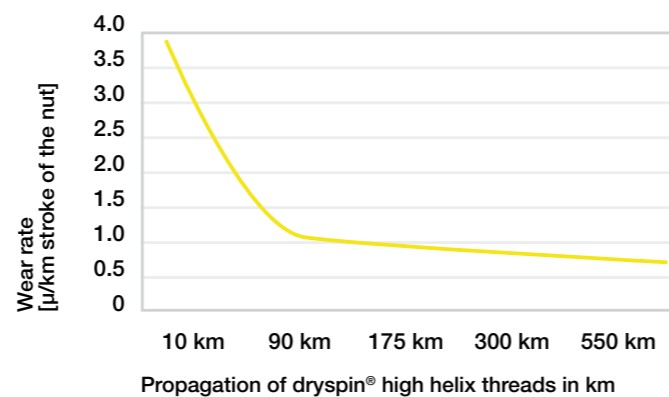

Wear test dryspin® high helix thread
DST 10x25, load 175N, 540mm stroke, 125rpm

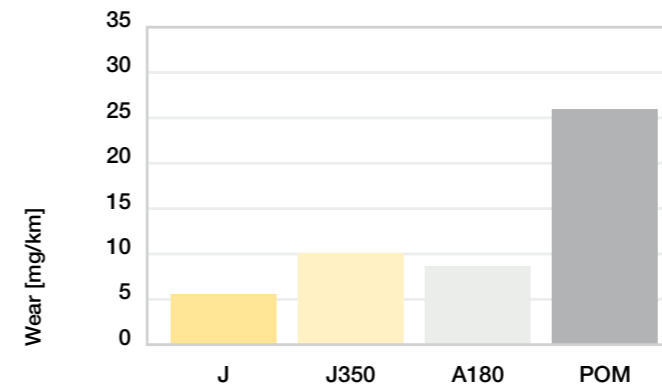

Wear test on C15 lead screw [mg/km]
Stroke 140mm, 50N, lead screw C15 rolled, 450rpm

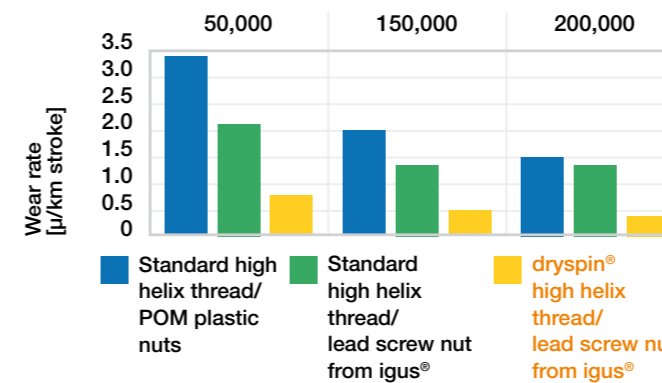

Wear-resistant high helix thread 10x50, dryspin® high helix thread / standard high helix thread, load 36N, 100rpm for 50,000/150,000/200,000 cycles

Correct choice of material

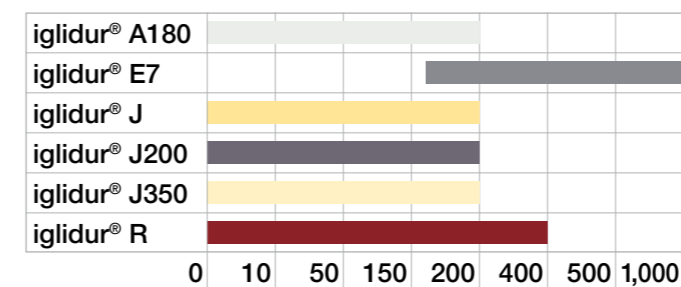

Speed [rpm]

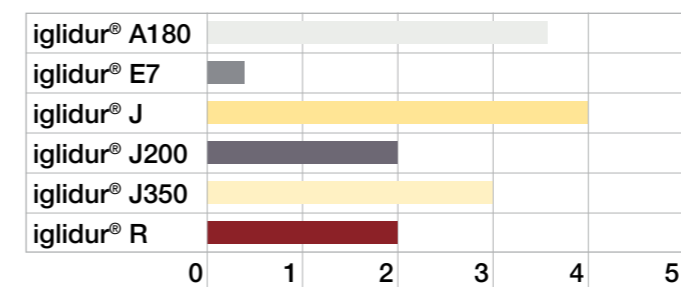

Surface pressure in thread [MPa]

igidur® J200 most suitable in combination with hard anodised aluminium

dry-tech® tribo-plastics

igus® high-performance polymers are used in all drylin® linear and drive units as well as lead screw drives. The lubrication is incorporated into the bearing material, rendering the bearing materials suitable for dry operation, i.e. they are maintenance-free for their entire service life.

Material selection

drylin® lead screw nuts are made from tribologically optimised materials. Already during the development phase, the focus is on optimising the friction properties of the drylin® lead screw drives, with the objective of attaining the lowest possible coefficient of wear and friction.

Service life

Every year, several hundred tests are set up and performed on test rigs in the igus® test laboratory. The results are incorporated into easily accessible online tools, where the service life and the required torque can be determined.

► www.igus.eu/leadscrew-expert

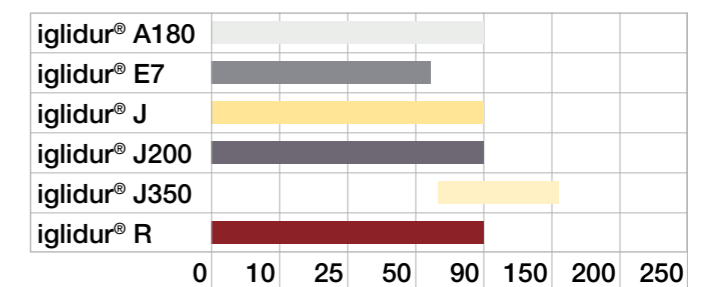

Temperature [°C]

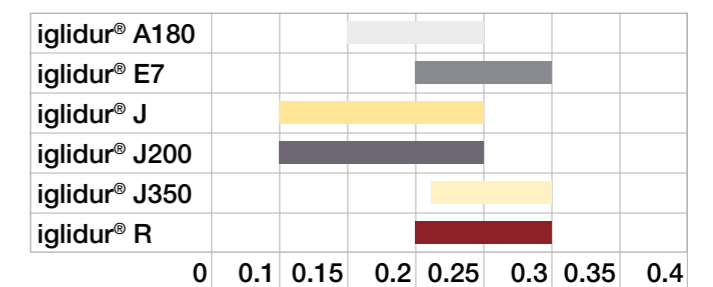

Coefficient of friction [µ]



Stainless steel, rolled, AISI 304



Aluminium, rolled (EN AW 6082)

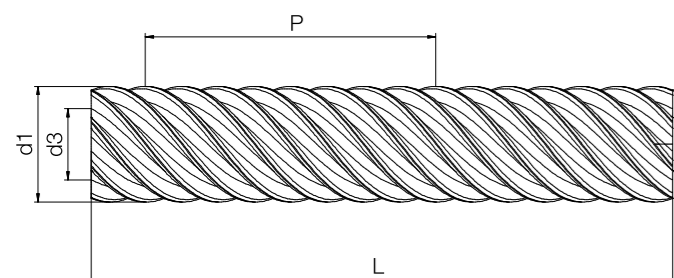

Technical data

Helix deviation	0.1mm to 300mm
Straightness (standard)	0.3mm to 300mm
Aligned	<0.1mm to 300mm

The tensile/compressive strength of the EN AW 6082 lead screw material is 160MPa per mm² (elongation limit 0.2mm).

Technical data

Thread	Hand of rotation		Material		Pitch P [mm]	Number of thread pitches	Pitch angle α [°]	Weight	
	right	left	Stainless steel	Aluminium				Stainless steel	Aluminium
			AISI 304	EN AW 6082				[kg/m]	[kg/m]
Ds4x2.4	●	–	●	–	2.4	2	10.81	0.10	–
Ds5x5	●	–	●	–	5.0	2	17.70	0.20	–
Ds6.35x2.54	●	●	●	–	2.54	2	7.26	0.25	–
Ds6.35x5.08	●	–	●	–	5.08	4	14.29	0.25	–
Ds6.35x12.7	●	–	●	–	12.7	4	32.48	0.25	–
Ds6.35x25.4	●	–	●	–	25.4	8	51.85	0.25	–
Ds8x10	●	●	●	●	10.0	4	21.70	0.40	0.14
Ds8x15	●	●	●	●	15.0	6	30.83	0.40	0.14
Ds8x24	●	–	●	–	24.0	8	43.70	0.40	–
Ds10x3	●	–	●	–	3.0	2	5.45	0.62	–
Ds10x12	●	●	●	●	12.0	4	21.54	0.62	0.21
Ds10x25	●	●	●	●	25.0	8	38.51	0.62	0.21
Ds10x50	●	●	●	●	50.0	10	57.86	0.62	0.21
Ds12x5	●	–	●	●	5.0	2	7.55	0.89	0.31
Ds12.7x12.7	●	–	●	–	12.7	4	17.65	0.90	–
Ds12x15	●	–	●	–	15.0	5	21.90	0.98	–
Ds12x25	●	–	●	●	25.0	8	33.55	0.89	0.31
Ds14x25	●	●	●	●	25.0	5	29.61	1.22	0.42
Ds14x30	●	–	●	●	30.0	6	34.30	1.22	0.42
Ds14x40.6	●	–	●	–	40.6	8	42.71	1.22	0.42
Ds16x35	●	–	●	●	35.0	7	34.85	1.59	0.54
Ds18x24	●	●	●	●	24.0	6	22.99	2.01	0.69

Available from stock
Upon request

Order key

Part number	Thread	Options
-------------	--------	---------

DST-LS-10X50-R-1000-ES

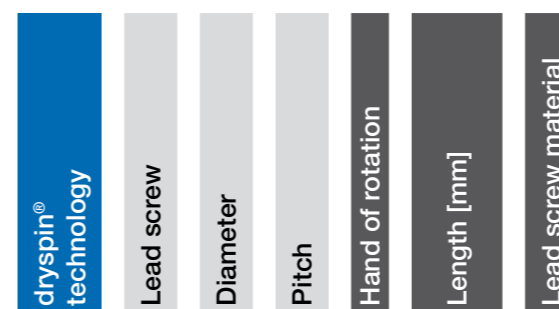

- Options:
- Hand of rotation
 - R: Right-hand thread
 - L: Left-hand thread
 - Length in mm: Freely selectable (see table)
 - Lead screw material
 - ES: Stainless steel, rolled
 - AL: Aluminium, rolled

Please contact us!

All drylin® leads screws can be custom machined. Please send us your drawing or configure online. We can then provide a quotation quickly.

► www.igus.eu/leadscrew-configurator

Dimensions [mm]

Outer Ø d1	Core Ø d3	Max. total length L		Part No.
		ES	AL	
–0.1	–0.1			
4.0 –0.05	3.0 –0.1	1,000	1,000	DST-LS-4X2.4-R-□-ES
5.0	3.30	1,000	–	DST-LS-5X5-R-□-ES New
6.35 –0.05	4.35 –0.05	1,000	1,000	DST-LS-6.35X2.54-□-ES
6.35 –0.05	4.85 –0.05	1,000	1,000	DST-LS-6.35X5.08-R-□-ES
6.35 –0.05	4.35 –0.05	1,000	1,000	DST-LS-6.35X12.7-R-□-ES
6.35 –0.05	4.15 –0.05	1,000	1,000	DST-LS-6.35X25.4-R-□-ES
8.0	5.63	1,000	1,000	DST-LS-8X10-□-ES
8.0	5.63	1,000	–	DST-LS-8X15-□-ES
8.0	5.55	1,000	–	DST-LS-8X24-R-□-ES New
10.0	7.85	3,000	–	DST-LS-10X3-R-□-ES New
10.0	6.95	3,000	1,000	DST-LS-10X12-□-ES
10.0	7.10	3,000	1,000	DST-LS-10X25-□-ES
10.0	7.35	3,000	1,000	DST-LS-10X50-□-ES
12.0	9.60	3,000	1,500	DST-LS-12X5-R-ES
12.7	9.60	3,000	–	DST-LS-12.7X12.7-R-□-ES New
12.0	9.00	3,000	–	DST-LS-12X15-R-□-ES New
12.0	8.95	3,000	1,500	DST-LS-12X25-R-□-ES
14.0	9.60	3,000	1,500	DST-LS-14X25-□-ES
14.0	9.60	3,000	1,500	DST-LS-14X30-R-□-ES
14.0	9.65	3,000	1,500	DST-LS-14X40.6-R-□-ES
16.0	11.60	3,000	1,500	DST-LS-16X35-R-□-ES
18.0	14.28	3,000	1,500	DST-LS-18X24-□-ES

Technical data

Thread	Hand of rotation		Material		Pitch P [mm]	Number of thread pitches	Pitch angle α [°]	Weight	
	right	left	Stainless steel	Aluminium				Stainless steel	Aluminium
			AISI 304	EN AW 6082				[kg/m]	[kg/m]
Ds18x40	●	●	●	●	40.0	8	35.55	2.01	0.69
Ds18x80	●	●	●	●	80.0	12	54.74	2.01	0.69
Ds18x100	●	●	●	●	100.0	12	60.51	2.01	0.69
Ds20x20	●	●	●	●	20.0	4	17.66	2.48	0.85
Ds20x50	●	–	●	●	50.0	8	38.51	2.48	0.85
Ds20x60	●	●	●	●	60.0	8	43.68	2.48	0.85
Ds20x80	●	●	●	●	80.0	12	55.07	2.48	0.85
Dx20x90	●	●	●	●	90.0	12	55.08	2.48	0.85

Dimensions [mm]

Outer Ø d1	Core Ø d3	Max. total length L		Part No.
		ES	AL	
–0.1	–0.1			
18.0	13.60	3,000	1,500	DST-LS-18X40-□-□-ES
18.0	14.00	3,000	1,500	DST-LS-18X80-□-□-ES
18.0	13.55	3,000	1,500	DST-LS-18X100-□-□-ES
20.0	15.60	3,000	1,500	DST-LS-20X20-□-□-ES
20.0	15.48	3,000	1,000	DST-LS-20X50-□-□-ES
20.0	15.55	3,000	1,500	DST-LS-20X60-□-□-ES
20.0	15.98	3,000	1,500	DST-LS-20X80-□-□-ES
20.0	15.55	3,000	1,500	DST-LS-20X90-□-□-ES



Available from stock

Upon request



Stainless steel, rolled, AISI 304

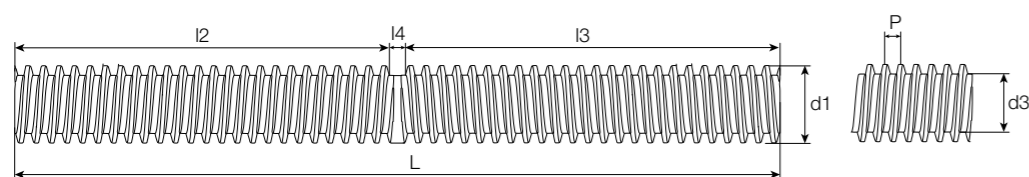

Technical data

Thread	Max. transferrable torque	Max. tensile strength	Material	Pitch P	Number of thread pitches	Pitch angle α
	[Nm]	[N]	Stainless steel AISI 304	[mm]		[°]
Ds10x12	2.0	450	●	12	4	21.54
Ds10x25	2.0	450	●	25	8	38.51
Ds10x50	2.0	450	●	50	10	57.86
Ds14x25	4.0	1,000	●	25	5	29.61
Ds18x24	7.5	1,600	●	24	6	22.99
Ds18x40	7.5	1,600	●	40	8	35.55
Ds18x80	7.5	1,600	●	80	12	54.74
Ds18x100	7.5	1,600	●	100	12	60.51

⁴⁶⁾ Non-usable thread transition⁴⁷⁾ Length right-hand thread (I3)⁴⁸⁾ Length left-hand thread (I2)
 Order key

Part number	Thread	Options
-------------	--------	---------

DST-LS-10X50-R/L-480-480-ES

dryspin® technology	Lead screw	Diameter	Pitch	Hand of rotation	⁴⁷⁾ Length right [mm]	⁴⁸⁾ Length left [mm]	Lead screw material
------------------------	------------	----------	-------	------------------	----------------------------------	---------------------------------	---------------------

Options:

⁴⁷⁾ I3: Length right-hand thread⁴⁸⁾ I2: Length left-hand thread

Length in mm: Freely selectable (see table)

Lead screw material

ES: Stainless steel, rolled

 Please contact us!

All drylin® leads screws can be custom machined. Please send us your drawing or configure online.

We can then provide a quotation quickly.

► www.igus.eu/leadscrew-configurator

Dimensions [mm]

Outer Ø d1	Core Ø d3	Thread transition	Max. thread length	Max. total length	Part No.	
-0.10	-0.10	I4 ⁴⁶⁾	I2 ⁴⁸⁾	I3 ⁴⁷⁾	L	
10	6.95	25	487	487	1,000	DST-LS-10X12-R/L-I2-I3-ES
10	7.10	25	487	487	1,000	DST-LS-10X25-R/L-I2-I3-ES
10	7.35	25	487	487	1,000	DST-LS-10X50-R/L-I2-I3-ES
14	9.60	25	987	987	2,000	DST-LS-14X25-R/L-I2-I3-ES
18	14.40	25	987	987	2,000	DST-LS-18X24-R/L-I2-I3-ES
18	13.60	25	987	987	2,000	DST-LS-18X40-R/L-I2-I3-ES
18	14.00	25	987	987	2,000	DST-LS-18X80-R/L-I2-I3-ES
18	13.55	25	987	987	2,000	DST-LS-18X100-R/L-I2-I3-ES

dryspin® technology | Lead screw nuts | Technical data



Highly efficient at all speeds:
iglidur® J

Thread	Efficiency	Coefficient of friction
	η	μ
Ds4x2.4	41–64	0.1–0.25
Ds5x5	52–74	0.1–0.25
Ds6.35x2.54	33–55	0.1–0.25
Ds6.35x5.08	47–70	0.1–0.25
Ds6.35x12.7	60–81	0.1–0.25
Ds6.35x25.4	57–81	0.1–0.25
Ds8x10	55–77	0.1–0.25
Ds8x15	60–81	0.1–0.25
Ds8x24	60–82	0.1–0.25
Ds10x3	27–48	0.1–0.25
Ds10x12	55–76	0.1–0.25
Ds10x25	61–82	0.1–0.25
Ds10x50	52–79	0.1–0.25
Ds12x5	34–56	0.1–0.25
Ds12.7x12.7	52–74	0.1–0.25
Ds12x15	55–77	0.1–0.25
Ds12x25	61–81	0.1–0.25
Ds14x25	60–80	0.1–0.25
Ds14x30	61–81	0.1–0.25
Ds14x40.6	61–82	0.1–0.25
Ds16x35	61–81	0.1–0.25
Ds18x24	56–77	0.1–0.25
Ds18x40	61–81	0.1–0.25
Ds18x80	55–80	0.1–0.25
Ds18x100	49–78	0.1–0.25
Ds20x20	52–74	0.1–0.25
Ds20x50	61–82	0.1–0.25
Ds20x60	60–82	0.1–0.25
Ds20x80	57–81	0.1–0.25
Ds20x90	55–80	0.1–0.25



For temperatures up to +150°C:
iglidur® J350

Thread	Efficiency	Coefficient of friction
	η	μ
Ds4x2.4	41–51	0.17–0.25
Ds5x5	52–62	0.17–0.25
Ds6.35x2.54	33–42	0.17–0.25
Ds6.35x5.08	47–57	0.17–0.25
Ds6.35x12.7	60–70	0.17–0.25
Ds6.35x25.4	57–69	0.17–0.25
Ds8x10	55–65	0.17–0.25
Ds8x15	60–70	0.17–0.25
Ds8x24	60–71	0.17–0.25
Ds10x3	35–48	0.17–0.25
Ds10x12	55–65	0.17–0.25
Ds10x25	61–71	0.17–0.25
Ds10x50	52–66	0.17–0.25
Ds12x5	34–43	0.17–0.25
Ds12.7x12.7	62–71	0.17–0.25
Ds12x15	55–65	0.17–0.25
Ds12x25	61–71	0.17–0.25
Ds14x25	60–70	0.17–0.25
Ds14x30	61–71	0.17–0.25
Ds14x40.6	61–71	0.17–0.25
Ds16x35	61–71	0.17–0.25
Ds18x24	56–66	0.17–0.25
Ds18x40	61–71	0.17–0.25
Ds18x80	55–68	0.17–0.25
Ds18x100	49–64	0.17–0.25
Ds20x20	52–62	0.17–0.25
Ds20x50	61–71	0.17–0.25
Ds20x60	60–71	0.17–0.25
Ds20x80	57–69	0.17–0.25
Ds20x90	55–68	0.17–0.25



For medium to high speeds:
iglidur® R

Thread	Efficiency	Coefficient of friction
	η	μ
Ds4x2.4	37–47	0.2–0.3
Ds5x5	47–58	0.2–0.3
Ds6.35x2.54	29–38	0.2–0.3
Ds6.35x5.08	42–53	0.2–0.3
Ds6.35x12.7	55–66	0.2–0.3
Ds6.35x25.4	50–64	0.2–0.3
Ds8x10	50–61	0.2–0.3
Ds8x15	55–66	0.2–0.3
Ds8x24	54–67	0.2–0.3
Ds10x3	23–32	0.2–0.3
Ds10x12	50–61	0.2–0.3
Ds10x25	55–67	0.2–0.3
Ds10x50	44–61	0.2–0.3
Ds12x5	29–39	0.2–0.3
Ds12.7x12.7	47–58	0.2–0.3
Ds12x15	50–61	0.2–0.3
Ds12x25	55–67	0.2–0.3
Ds14x25	60–72	0.2–0.3
Ds14x30	61–74	0.2–0.3
Ds14x40.6	55–67	0.2–0.3
Ds16x35	61–74	0.2–0.3
Ds18x24	51–62	0.2–0.3
Ds18x40	61–74	0.2–0.3
Ds18x80	55–71	0.2–0.3
Ds18x100	40–58	0.2–0.3
Ds20x20	52–65	0.2–0.3
Ds20x50	55–67	0.2–0.3
Ds20x60	60–74	0.2–0.3
Ds20x80	50–64	0.2–0.3
Ds20x90	55–71	0.2–0.3



FDA-compliant for the food/
pharmaceutical industry: iglidur® A180

Thread	Efficiency	Coefficient of friction
	η	μ
Ds4x2.4	41–54	0.15–0.25
Ds5x5	52–65	0.15–0.25
Ds6.35x2.54	33–45	0.15–0.25
Ds6.35x5.08	47–61	0.15–0.25
Ds6.35x12.7	60–73	0.15–0.25
Ds6.35x25.4	57–72	0.15–0.25
Ds8x10	55–68	0.15–0.25
Ds8x15	60–73	0.15–0.25
Ds8x24	60–74	0.15–0.25
Ds10x3	38–48	0.15–0.25
Ds10x12	55–68	0.15–0.25
Ds10x25	61–74	0.15–0.25
Ds10x50	52–70	0.15–0.25
Ds12x5	34–46	0.15–0.25
Ds12.7x12.7	65–74	0.15–0.25
Ds12x15	55–68	0.15–0.25
Ds12x25	61–73	0.15–0.25
Ds14x25	60–72	0.15–0.25
Ds14x30	61–74	0.15–0.25
Ds14x40.6	61–74	0.15–0.25
Ds16x35	61–74	0.15–0.25
Ds18x24	56–69	0.15–0.25
Ds18x40	61–74	0.15–0.25
Ds18x80	55–71	0.15–0.25
Ds18x100	49–68	0.15–0.25
Ds20x20	52–65	0.15–0.25
Ds20x50	61–74	0.15–0.25
Ds20x60	60–74	0.15–0.25
Ds20x80	57–72	0.15–0.25
Ds20x90	55–71	0.15–0.25



For high speeds:
iglidur® E7



The specialist on hard anodised
aluminium: iglidur® J200

Thread	Efficiency	Coefficient of friction
	η	μ
Ds6.35x2.54	33–55	0.2–0.3
Ds6.35x5.08	47–70	0.2–0.3
Ds6.35x12.7	60–81	0.2–0.3
Ds6.35x25.4	57–81	0.2–0.3
Ds8x10	55–77	0.2–0.3
Ds8x15	60–81	0.2–0.3
Ds10x3	23–32	0.2–0.3
Ds10x12	55–76	0.2–0.3
Ds10x25	61–82	0.2–0.3
Ds10x50	52–79	0.2–0.3
Ds12x5	34–56	0.2–0.3
Ds14x25	60–80	0.2–0.3
Ds14x30	61–81	0.2–0.3
Ds16x35	–	–
Ds18x24	–	–
Ds18x40	–	–
Ds18x80	–	–
Ds18x100	–	–
Ds20x20	–	–
Ds20x50	–	–
Ds20x60	–	–
Ds20x80	–	–
Ds20x90	–	–

Thread	Efficiency	Coefficient of friction
	η	μ
Ds6.35x2.54	–	–
Ds6.35x5.08	–	–
Ds6.35x12.7	–	–
Ds6.35x25.4	–	–
Ds8x10	–	–
Ds8x15	–	–
Ds10x3	–	–
Ds10x12	–	–
Ds10x25	–	–
Ds10x50	–	–
Ds12x5	–	–
Ds14x25	–	–
Ds14x30	–	–
Ds16x35	61–71	0.1–0.25
Ds18x24	56–77	0.1–0.25
Ds18x40	61–71	0.1–0.25
Ds18x80	55–68	0.1–0.25
Ds18x100	49–64	0.1–0.25
Ds20x20	52–62	0.1–0.25
Ds20x50	52–62	0.1–0.25
Ds20x60	60–71	0.1–0.25
Ds20x80	57–69	0.1–0.25
Ds20x90	55–68	0.1–0.25

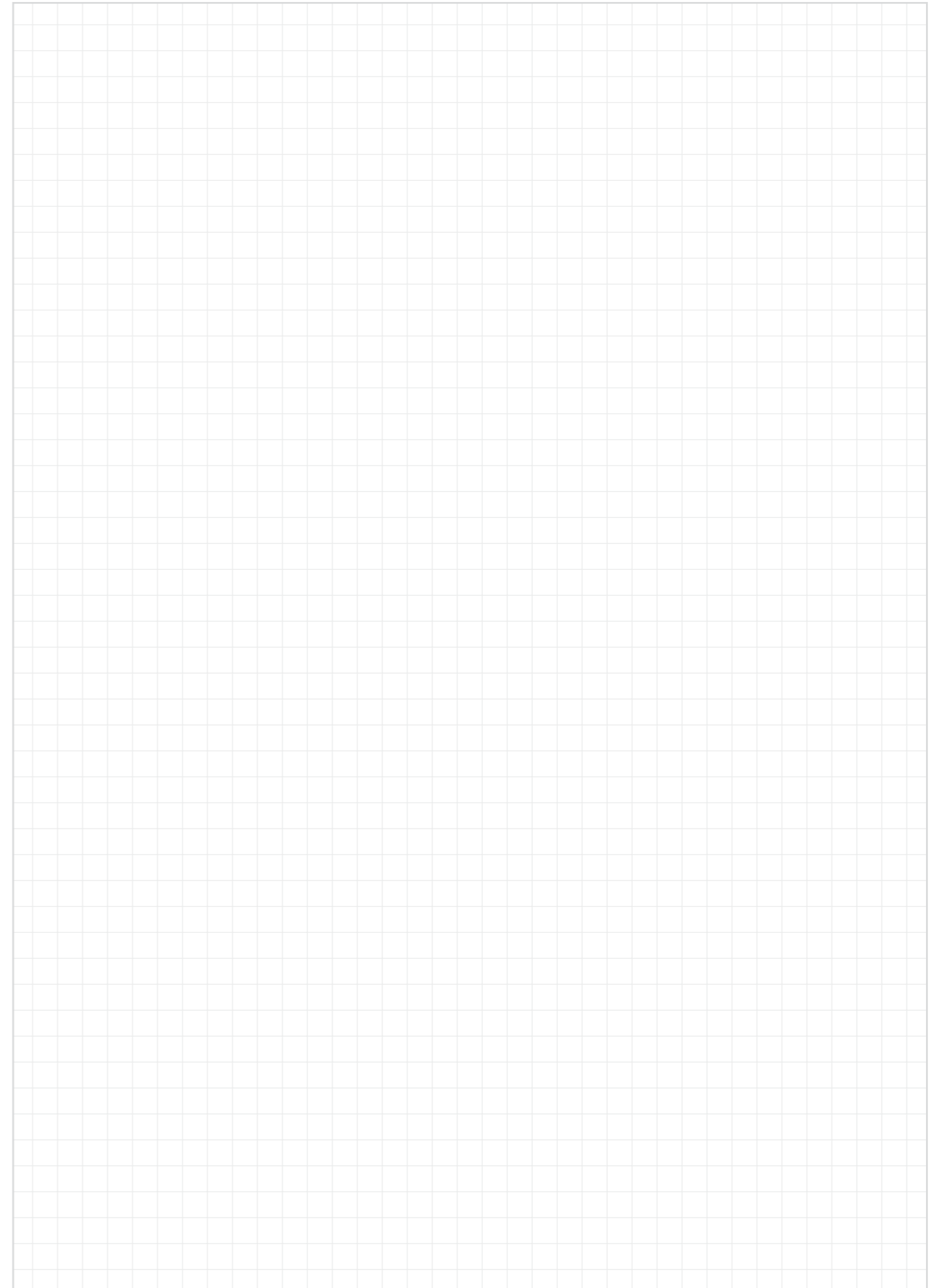

Lead screw nuts, cylindrical (form S)

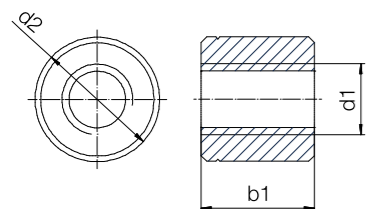

Technical data

Thread	Hand of rotation		Effective supporting surface [mm²]	Max. stat. axial F [N] igidur®		
	right	left		J / J350 / A180	R	E7
Ds4x2.4	●	–	60	152	152	–
Ds5x5	●	–	57	152	152	–
Ds6.35x2.54	●	●	172	152	152	86
Ds6.35x5.08	●	–	135	152	152	68
Ds6.35x12.7	●	–	67	152	152	34
Ds6.35x25.4	●	–	74	152	152	24
Ds8x10	●	●	122	304	244	61
Ds8x15	●	●	123	308	244	61
Ds8x24	●	–	104	260	208	–
Ds10x3	●	–	410	1,025	820	–
Ds10x12	●	●	274	685	541	72
Ds10x25	●	●	249	623	499	125
Ds10x50	●	●	144	361	289	137
Ds12x5	●	–	398	995	796	–
Ds12.7x12.7	●	–	462	1,155	924	–
Ds12x15	●	–	712	1,113	891	–
Ds12x25	●	–	385	963	770	–
Ds14x25	●	●	444	1,110	888	–
Ds14x30	●	–	440	1,101	881	–
Ds14x40.6	●	–	434	1,095	868	–
Ds16x35	●	–	610	1,526	1,221	–
Ds18x24	●	●	844	2,110	1,688	–

Order key

Type d2 b1 Thread

DST-□ S R M-1413DS10X12

dryspin® technology	igidur® material	Form S	Hand of rotation	Metric	Outer Ø [mm]	Length [mm]	Thread type	Diameter [mm]	Pitch
---------------------	------------------	--------	------------------	--------	--------------	-------------	-------------	---------------	-------

Options:
Hand of rotation
R: Right-hand thread
L: Left-hand thread

- J** High efficiency at all speeds
- J350** For temperatures up to +150°C
- R** The cost-effective option for high volume
- A180** FDA-compliant for the food and pharmaceutical industries
- E7** For high speeds

Dimensions [mm]

d1 ¹⁵⁶⁾	d2 ¹⁵⁶⁾	b1 ¹⁵⁶⁾	Weight [g] igidur®					Part No.
			J	J350	R	A180	E7	
4	14	13	2.74	2.65	2.55	2.68	–	DST-□SRM-131315DS4X2.4
5	14	13	2.4	2.3	2.2	2.3	–	DST-□SRM-1413DS5X5 New
6.35	14	13	2.4	2.3	2.2	2.3	1.67	DST-□S□M-1413DS6.35X2.54
6.35	14	13	2.4	2.3	2.2	2.3	1.67	DST-□SRM-1413DS6.35X5.08
6.35	14	13	2.4	2.3	2.2	2.3	1.67	DST-□SRM-1413DS6.35X12.7
6.35	14	13	2.4	2.3	2.2	2.3	1.67	DST-□SRM-1413DS6.35X25.4
8	18	12	3.7	3.5	3.4	3.6	2.57	DST-□S□M-1812DS8X10
8	18	12	3.7	3.5	3.4	3.6	2.57	DST-□S□M-1812DS8X15
8	18	12	3.7	3.5	3.4	3.6	–	DST-□SRM-1812DS8X24 New
10	22	20	9.0	8.7	8.4	8.8	–	DST-□SRM-2220DS10X3 New
10	22	20	9.0	8.7	8.4	8.8	6.33	DST-□S□M-2220DS10X12
10	22	20	9.0	8.7	8.4	8.8	6.33	DST-□S□M-2220DS10X25
10	22	20	9.0	8.7	8.4	8.8	6.33	DST-□S□M-2220DS10X50
12	26	24	14.9	14.4	13.9	14.6	–	DST-□SRM-2624DS12X5
12	26	24	14.9	14.4	13.9	14.6	–	DST-□SRM-2624DS12.7X12.7 New
12	26	24	14.9	14.4	13.6	14.6	–	DST-□SRM-2624DS12X15 New
12	26	24	14.9	14.4	13.9	14.6	–	DST-□SRM-2624DS12X25
14	30	27	22.2	21.5	20.8	21.8	–	DST-□S□M-3027DS14X25
14	30	27	22.2	21.5	20.8	21.8	–	DST-□SRM-3027DS14X30
14	30	27	22.2	21.5	20.8	21.8	–	DST-□SRM-3027DS14X40.6
16	36	32	38.9	37.6	36.3	38.2	–	DST-□SRM-3632DS16X35
18	40	36	53.8	52.0	50.1	52.7	–	DST-□S□M-4036DS18X24

¹⁵⁶⁾ Tolerances according to DIN ISO 2768-1, tolerance class m (medium)

Technical data

Thread	Hand of rotation		Effective supporting surface [mm ²]	Max. stat. axial F [N]		
	right	left		iglidur®		
			J / J350 / A180	R	E7	
Ds18x40	●	●	786	1,966	1,573	–
Ds18x80	●	●	543	1,357	1,086	–
Ds18x100	●	●	476	1,191	953	–
Ds20x20	●	●	984	2,460	1,968	–
Ds20x50	●	–	1007	2,517	2,014	–
Ds20x60	●	●	663	1,657	1,325	–
Ds20x80	●	●	686	1,715	1,372	–
Ds20x90	●	●	610	1,657	1,220	–

Dimensions [mm]

d1 ¹⁵⁶⁾	d2 ¹⁵⁶⁾	b1 ¹⁵⁶⁾	Weight [g]				Part No.	
			iglidur®					
			J	J350	R	A180	E7	
18	40	36	53.8	52.0	50.1	52.7	–	DST-□S□M-4036DS18X40
18	40	36	53.8	52.0	50.1	52.7	–	DST-□S□M-4036DS18X80
18	40	36	53.8	52.0	50.1	52.7	–	DST-□S□M-4036DS18X100
20	45	40	76.1	73.5	71.0	74.5	–	DST-□S□M-4540DS20X20
20	45	40	76.1	73.5	71.0	74.5	–	DST-□SRM-4540DS20X50
20	45	40	76.1	73.5	71.0	74.5	–	DST-□S□M-4540DS20X60
20	45	40	76.1	73.5	71.0	74.5	–	DST-□S□M-4540DS20X80
20	45	40	76.1	73.5	71.0	74.5	–	DST-□S□M-4540DS20X90

¹⁵⁶⁾ Tolerances according to DIN ISO 2768-1, tolerance class m (medium)

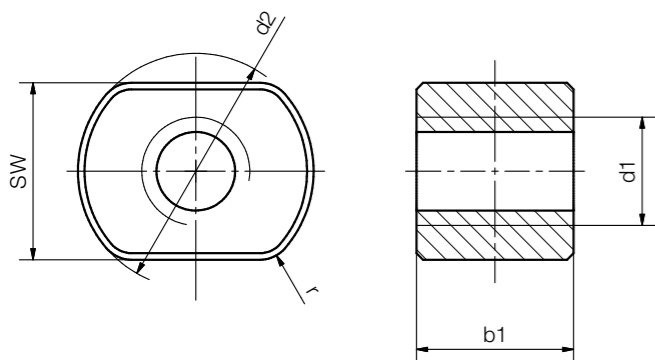
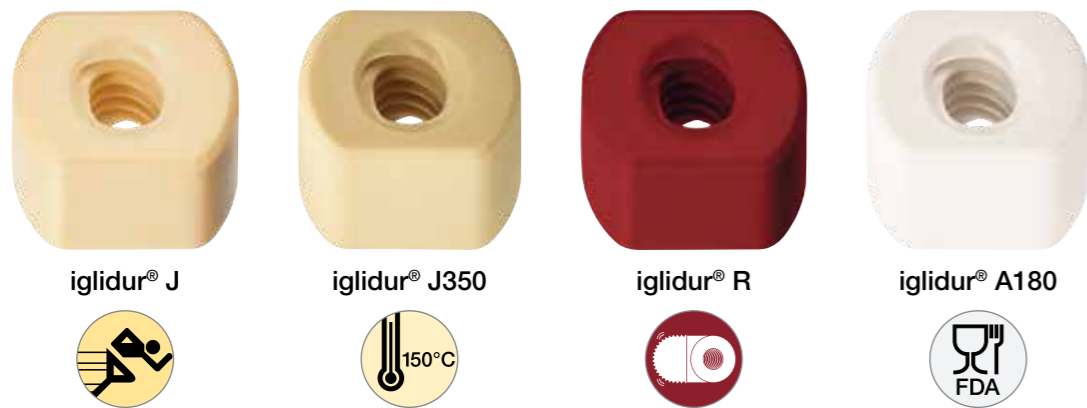

Technical data

Thread	Hand of rotation		Effective support surface [mm²]	Max. stat. axial F [N] igidur®			
	right	left		J	J350	R	A180
DS10x12	●	●	271	677	677	541	677
DS10x25	●	●	249	623	623	499	623
DS10x50	●	●	144	361	361	289	361
DS12x5	●	–	391	977	977	782	977
DS12x15	●	–	633	990	990	792	990
DS12x25	●	–	385	964	964	771	964
DS14x25	●	●	440	1,101	1,101	881	1,101
DS14x30	●	–	440	1,101	1,101	881	1,101
DS14x40.6	●	–	430	1,075	1,075	860	1,075
DS16x35	●	–	610	1,526	1,526	1,221	1,526
DS18x24	●	●	824	2,061	2,061	1,649	2,061
DS18x40	●	●	786	1,966	1,966	1,573	1,966
DS18x80	●	●	543	1,357	1,357	1,086	1,357
DS18x100	●	●	476	1,191	1,191	953	1,191
DS20x20	●	●	984	2,460	2,460	1,968	2,460
DS10x50	●	●	795	1,988	1,988	1,590	1,988
DS20x50	●	–	663	1,657	1,657	1,325	1,657
DS20x60	●	●	663	1,657	1,657	1,325	1,657
DS20x80	●	●	697	1,742	1,742	1,393	1,742
DS20x90	●	●	663	1,657	1,657	1,325	1,657

Order key

Type	SW	d2	b1	Thread
DST-□ S R M-17 22 20 DS 10X12				
dryspin® technology	igidur® material	Form S	Hand of rotation	Metric
			Spanner flat [mm]	Outer Ø [mm]
			Length [mm]	Thread type
			Diameter [mm]	Pitch

Options:
Hand of rotation
R: Right-hand thread
L: Left-hand thread

J	High efficiency at all speeds
J350	For temperatures up to +150°C
R	The cost-effective option for high volume
A180	FDA-compliant for the food and pharmaceutical industries

Dimensions [mm]

d1 ¹⁵⁶⁾	d2 ¹⁵⁶⁾	b1 ¹⁵⁶⁾	SW	Weight [g] igidur®				Part No.
				J	J350	R	A180	
10	22	20	17	6.65	6.42	6.20	6.51	DST-□S□M-172220DS10x12
10	22	20	17	6.65	6.42	6.20	6.51	DST-□S□M-172220DS10x25
10	22	20	17	6.65	6.42	6.20	6.51	DST-□S□M-172220DS10x50
12	26	24	19	10.90	10.53	10.17	10.68	DST-□SRM-192624DS12x5
12	26	24	19	10.90	10.50	10.20	10.70	DST-□SRM-192624DS12x15 New
12	26	24	19	10.90	10.53	10.17	10.68	DST-□SRM-192624DS12x25
14	30	27	25	16.05	15.51	14.97	15.73	DST-□S□M-253027DS14x25
14	30	27	25	16.05	15.51	14.97	15.73	DST-□SRM-253027DS14x30
14	30	32	25	19.02	18.39	17.75	18.64	DST-□SRM-253027DS14x40.6
16	36	36	27	33.03	31.92	30.81	32.36	DST-□SRM-273632DS16x35
18	40	36	27	40.11	38.76	37.41	39.30	DST-□S□M-274036DS18x24
18	40	36	27	40.11	38.76	37.41	39.30	DST-□S□M-274036DS18x40
18	40	36	27	40.11	38.76	37.41	39.30	DST-□S□M-274036DS18x80
18	40	40	27	44.56	43.07	41.57	43.67	DST-□S□M-274036DS18x100
20	45	40	30	57.34	55.42	53.49	56.19	DST-□S□M-304540DS20x20
20	45	40	30	57.34	55.42	53.49	56.19	DST-□S□M-304540DS10x50
20	45	40	30	57.34	55.42	53.49	56.19	DST-□S□M-304540DS20x50
20	45	40	30	57.34	55.42	53.49	56.19	DST-□S□M-304540DS20x60
20	45	40	30	57.34	55.42	53.49	56.19	DST-□S□M-304540DS20x80
20	45	40	30	57.34	55.42	53.49	56.19	DST-□S□M-304540DS20x90

¹⁵⁶⁾ Tolerances according to DIN ISO 2768-1, tolerance class m (medium)

Lead screw nuts with flange (form F)

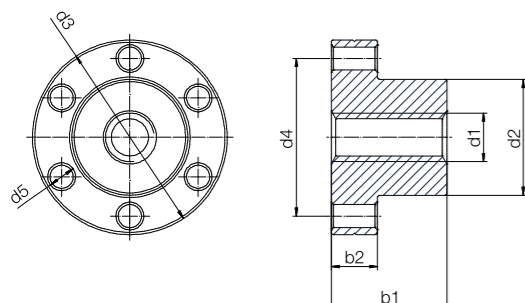
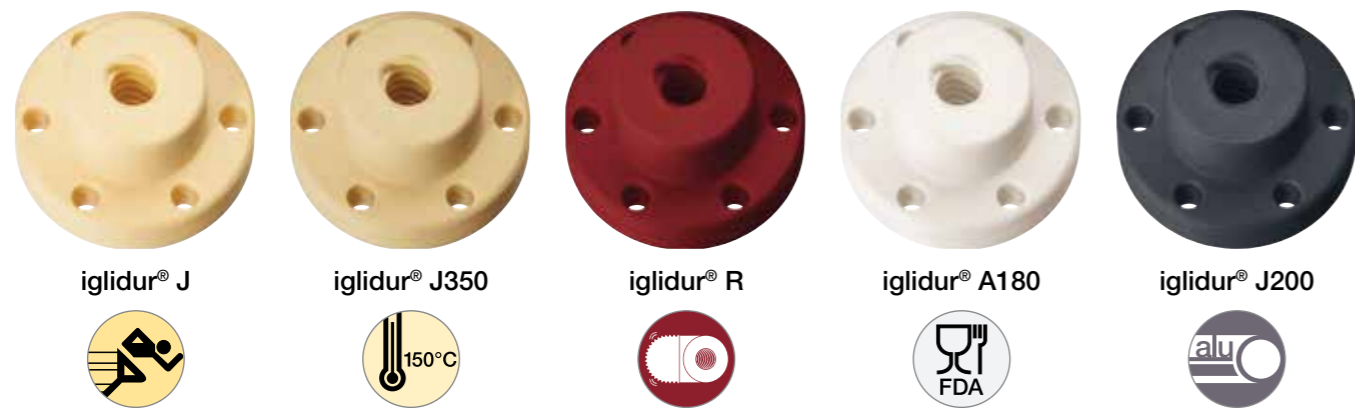

Technical data

Thread	Hand of rotation		Effective supporting surface [mm²]	Max. stat. axial F [N]		
	right	left		igidur®		
				J / J350 / A180	R	J200
Ds4x2.4	●	–	69	125	125	–
Ds5x5	●	–	66	152	152	–
Ds6.35x2.54	●	●	199	125	125	–
Ds6.35x5.08	●	–	156	125	125	–
Ds6.35x12.7	●	–	78	125	125	–
Ds6.35x25.4	●	–	86	125	125	–
Ds8x10	●	●	203	508	406	–
Ds8x15	●	●	205	635	507	–
Ds8x24	●	–	173	432.5	346	–
Ds10x3	●	●	512	1,280	1,024	–
Ds10x12	●	●	343	845	677	–
Ds10x25	●	●	312	780	623	–
Ds10x50	●	●	181	453	361	–
Ds12x5	●	–	581	1,425	1,140	–
Ds12.7x12.7	●	–	599	1,497.5	1,198	–
Ds12x15	●	–	923	1,443	1,155	–
Ds12x25	●	–	562	1,405	1,124	–
Ds14x25	●	●	576	1,428	1,142	–
Ds14x30	●	–	571	1,428	1,142	–
Ds14x40.6	●	–	434	1,085	868	–
Ds16x35	●	–	668	1,670	1,335	1,336

Order key

Type d2 b1 Thread

DST-□ F R M-25 25DS 10X12

dryspin® technology	igidur® material	Form F	Hand of rotation	Metric	Outer Ø [mm]	Length [mm]	Thread type	Diameter [mm]	Pitch
	J								
	J350								
	R								
	A180								
	J200								

Options:
Hand of rotation
R: Right-hand thread
L: Left-hand thread

- J** High efficiency at all speeds
- J350** For temperatures up to +150°C
- R** The cost-effective option for high volume
- A180** FDA-compliant for the food and pharmaceutical industries
- J200** The specialist on hard anodised aluminium

Dimensions [mm]

d1 ¹⁵⁶⁾	d2 ¹⁵⁶⁾	d3	d4	d5	b1 ¹⁵⁶⁾	b2	Weight [g]					Part No.
							igidur®					
							J	J350	R	A180	J200	
4.0	13	25	15	3.2	15	5	7.6	7.35	7.09	7.45	–	DST-□FRM-1315DS4X2.4
5.0	13	25	19	3.2	15	5	4.9	4.8	4.6	4.8	–	DST-□FRM-1315DS5X5 New
6.35	13	25	19	3.2	15	5	4.9	4.8	4.6	4.8	–	DST-□F□M-1315DS6.35X2.54
6.35	13	25	19	3.2	15	5	4.9	4.8	4.6	4.8	–	DST-□FRM-1315DS6.35X5.08
6.35	13	25	19	3.2	15	5	4.9	4.8	4.6	4.8	–	DST-□FRM-1315DS6.35X12.7
6.35	13	25	19	3.2	15	5	4.9	4.8	4.6	4.8	–	DST-□FRM-1315DS6.35X25.4
8	20	36	28	4	20	8	12.3	11.9	11.5	12.0	–	DST-□F□M-2020DS8X10
8	20	36	28	4	20	8	12.3	11.9	11.5	12.0	–	DST-□F□M-2020DS8X15
8	20	36	28	4	20	8	12.3	11.9	11.5	12.0	–	DST-□FRM-2020DS8X24 New
10	25	42	34	5	25	10	28.7	27.7	26.8	28.1	–	DST-□FRM-2525DS10X3 New
10	25	42	34	5	25	10	28.7	27.7	26.8	28.1	–	DST-□F□M-2525DS10X12
10	25	42	34	5	25	10	28.7	27.7	26.8	28.1	–	DST-□F□M-2525DS10X25
10	25	42	34	5	25	10	28.7	27.7	26.8	28.1	–	DST-□F□M-2525DS10X50
12	28	48	38	6	35	12	47.6	46.0	44.4	46.6	–	DST-□FRM-2835DS12X5
12	28	48	38	6	35	18	47.6	46.0	44.4	46.6	–	DST-□FRM-2835DS12.7X12.7 New
12	28	48	38	6	35	18	47.6	46.0	44.4	46.6	–	DST-□FRM-2835DS12X15 New
12	28	48	38	6	35	18	47.6	46.0	44.4	46.6	–	DST-□FRM-2835DS12X25
14	28	48	38	6	35	12	45.4	43.9	42.4	44.5	–	DST-□F□M-2835DS14X25
12	28	48	38	6	35	18	45.4	43.9	42.4	44.5	–	DST-□FRM-2835DS14X30
14	28	48	38	6	35	12	45.4	43.9	42.4	44.5	–	DST-□FRM-2835DS14X40.6
16	28	48	38	6	35	12	43.0	41.5	40.1	42.1	50	DST-□FRM-2835DS16X35

¹⁵⁶⁾ Tolerances according to DIN ISO 2768-1, tolerance class m (medium)

Technical data

Thread	Hand of rotation		Effective supporting surface [mm²]	Max. stat. axial F [N]		
	right	left		iglidur®		
				J / J350 / A180	R	J200
Ds18x24	●	●	844	2,110	1,688	1,688
Ds18x40	●	●	764	1,910	1,529	1,528
Ds18x80	●	●	528	1,320	1,056	1,056
Ds18x100	●	●	463	1,158	926	926
Ds20x20	●	●	1,083	2,708	2,165	2166
Ds20x50	●	–	729	1,823	1,458	1,750
Ds20x60	●	●	729	1,823	1,458	1,458
Ds20x80	●	●	755	1,888	1,510	1,510
Ds20x90	●	●	671	1,678	1,342	1,342

Dimensions [mm]

d1 ¹⁵⁶⁾	d2 ¹⁵⁶⁾	d3	d4	d5	b1 ¹⁵⁶⁾	b2	Weight [g]					Part No.
							iglidur®					
							J	J350	R	A180	J200	
18	28	48	38	6	35	12	50.9	49.2	47.4	49.8	48	DST-□F□M-2835DS18X24
18	28	48	38	6	35	12	50.9	49.2	47.4	49.8	48	DST-□F□M-2835DS18X40
18	28	48	38	6	35	12	50.9	49.2	47.4	49.8	48	DST-□F□M-2835DS18X80
18	28	48	38	6	35	12	50.9	49.2	47.4	49.8	48	DST-□F□M-2835DS18X100
20	32	55	45	7	44	12	60.2	58.2	56.2	59.0	73	DST-□F□M-3244DS20X20
20	32	55	45	7	44	12	60.2	58.2	56.2	59.0	73	DST-□F□M-3244DS20X50
20	32	55	45	7	44	12	60.2	58.2	56.2	59.0	73	DST-□F□M-3244DS20X60
20	32	55	45	7	44	12	60.2	58.2	56.2	59.0	73	DST-□F□M-3244DS20X80
20	32	55	45	7	44	12	60.2	58.2	56.2	59.0	73	DST-□F□M-3244DS20X90

¹⁵⁶⁾ Tolerances according to DIN ISO 2768-1, tolerance class m (medium)



iglidur® J



iglidur® J350

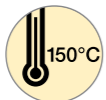

iglidur® R



iglidur® A180

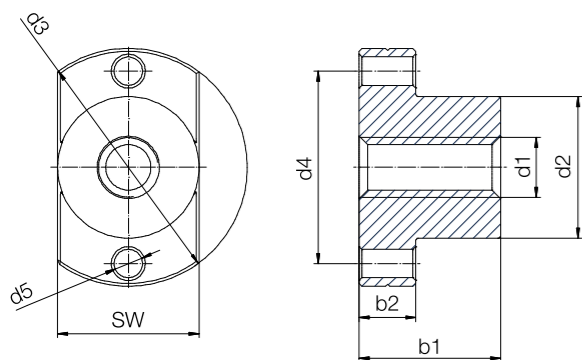

Technical data

Thread	Hand of rotation		Effective supporting surface [mm²]	Max. stat. axial F [N] iglidur®	
	right	left		J / J350 / A180	R
Ds4x2.4	●	–	69	125	125
Ds5x5	●	–	66	152	152
Ds6.35x2.54	●	●	199	125	125
Ds6.35x5.08	●	–	156	125	125
Ds6.35x12.7	●	–	78	125	125
Ds6.35x25.4	●	–	114	125	125
Ds8x10	●	●	203	507	406
Ds8x15	●	●	205	513	410
Ds8x24	●	●	173	432.5	346
Ds10x12	●	●	343	858	686
Ds10x25	●	●	312	779	623
Ds10x50	●	●	253	632	506
Ds12x5	●	–	581	1,452	1,162
Ds12x15	●	–	923	1,443	1,155
Ds12x25	●	–	562	1,405	1,124
Ds14x25	●	●	576	1,440	1,152
Ds14x30	●	–	571	1,427	1,142
Ds14x40.6	●	–	562	1,405	1,124
Ds16x35	●	–	668	1,669	1,335
Ds18x24	●	●	821	2,053	1,643
Ds18x40	●	●	764	1,911	1,529

Order key

Type	SW	d2	b1	Thread
------	----	----	----	--------

DST-□ F R M-25 25 25 DS 10X12

dryspin® technology	iglidur® material	Form F	Hand of rotation	Metric	Spanner flat [mm]	Outer Ø [mm]	Length [mm]	Thread type	Diameter [mm]	Pitch
---------------------	-------------------	--------	------------------	--------	-------------------	--------------	-------------	-------------	---------------	-------

Options:
Hand of rotation
R: Right-hand thread
L: Left-hand thread

- J** High efficiency at all speeds
- J350** For temperatures up to +150°C
- R** The cost-effective option for high volume
- A180** FDA-compliant for the food and pharmaceutical industries

Dimensions [mm]

d1 ¹⁵⁶⁾	d2 ¹⁵⁶⁾	d3	d4	d5	b1 ¹⁵⁶⁾	b2	SW	Weight [g] iglidur®				Part No.
								J	J350	R	A180	
4.0	13	25	19	3.2	15	5	13	4.1	3.98	3.84	4.04	DST-□FRM-131315DS4X2.4
5.0	13	25	19	3.2	15	5	13	3.7	3.6	3.4	3.6	DST-□FRM-131315DS5X5
6.35	13	25	19	3.2	15	5	13	3.7	3.6	3.4	3.6	DST-□F□M-131315DS6.35X2.54
6.35	13	25	19	3.2	15	5	13	3.7	3.6	3.4	3.6	DST-□FRM-131315DS6.35X5.08
6.35	13	25	19	3.2	15	5	13	3.7	3.6	3.4	3.6	DST-□FRM-131315DS6.35X12.7
6.35	13	25	19	3.2	15	5	13	3.7	3.6	3.4	3.6	DST-□FRM-131315DS6.35X25.4
8	20	36	28	4	20	8	20	12.7	12.3	11.8	12.4	DST-□F□M-202020DS8X10
8	20	36	28	4	20	8	20	12.7	12.3	11.8	12.4	DST-□F□M-202020DS8X15
8	20	36	28	4	20	8	20	12.7	12.3	11.8	12.4	DST-□F□M-202020DS8X24
10	25	42	34	5	25	10	25	23.7	22.9	22.1	23.2	DST-□F□M-252525DS10X12
10	25	42	34	5	25	10	25	23.7	22.9	22.1	23.2	DST-□F□M-252525DS10X25
10	25	42	34	5	25	10	25	23.7	22.9	22.1	23.2	DST-□F□M-252525DS10X50
12	28	48	38	6	35	12	28	39.2	37.9	36.6	38.4	DST-□FRM-282835DS12X5
12	28	48	38	6	35	18	28	39.2	37.9	36.6	38.4	DST-□FRM-282835DS12X15
12	28	48	38	6	35	12	28	39.2	37.9	36.6	38.4	DST-□FRM-282835DS12X25
14	28	48	38	6	35	12	28	37.1	35.9	34.6	36.4	DST-□F□M-282835DS14X25
14	28	48	38	6	35	12	28	37.1	35.9	34.6	36.4	DST-□FRM-282835DS14X30
14	28	48	38	6	35	12	28	37.1	35.9	34.6	36.4	DST-□FRM-282835DS14X40.6
16	28	48	38	6	35	12	28	34.6	33.5	32.3	33.9	DST-□FRM-282835DS16X35
18	28	48	38	6	35	12	28	31.9	30.8	29.7	31.2	DST-□F□M-282835DS18X24
18	28	48	38	6	35	12	28	31.9	30.8	29.7	31.2	DST-□F□M-282835DS18X40

¹⁵⁶⁾ Tolerances according to DIN ISO 2768-1, tolerance class m (medium)

Technical data

Thread	Hand of rotation		Effective supporting surface [mm ²]	Max. stat. axial F [N] iglidur®	
	right	left		J / J350 / A180	R
Ds18x80	●	●	528	1,319	1,056
Ds18x100	●	●	463	1,158	926
Ds20x20	●	●	1,083	2,707	2,165
Ds20x50	●	–	729	1,822	1,458
Ds20x60	●	●	729	1,822	1,458
Ds20x80	●	●	755	1,888	1,510
Ds20x90	●	●	671	1,678	1,342

Dimensions [mm]

d1 ¹⁵⁶⁾	d2 ¹⁵⁶⁾	d3	d4	d5	b1 ¹⁵⁶⁾	b2	SW	Weight [g] iglidur®				Part No.
								J	J350	R	A180	
18	28	48	38	6	35	12	28	31.9	30.8	29.7	31.2	DST-□F□M-282835DS18X80
18	28	48	38	6	35	12	28	31.9	30.8	29.7	31.2	DST-□F□M-282835DS18X100
20	32	55	45	7	44	12	32	49.2	47.6	45.9	48.2	DST-□F□M-323244DS20X20
20	32	55	45	7	44	12	32	49.2	47.6	45.9	48.2	DST-□F□M-323244DS20X50
20	32	55	45	7	44	12	32	49.2	47.6	45.9	48.2	DST-□F□M-323244DS20X60
20	32	55	45	7	44	12	32	49.2	47.6	45.9	48.2	DST-□F□M-323244DS20X80
20	32	55	45	7	44	12	32	49.2	47.6	45.9	48.2	DST-□F□M-323244DS20X90

¹⁵⁶⁾ Tolerances according to DIN ISO 2768-1, tolerance class m (medium)

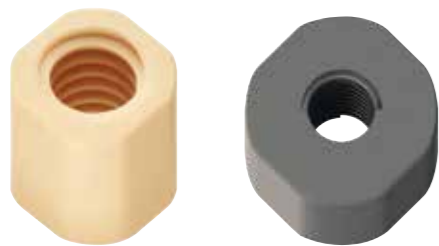

Images exemplary

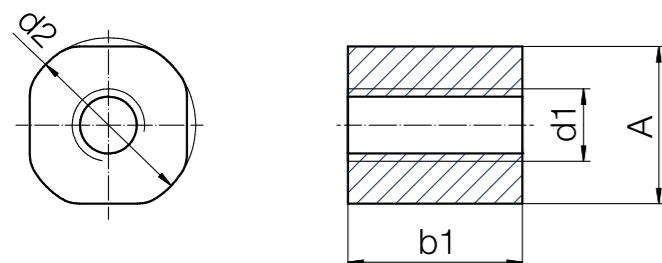

Technical data

Thread	Hand of rotation		Effective supporting surface [mm²]	Max. stat. axial F [N]
	right	left		
Ds4x2.4	●	–	53	152
Ds5x5	●	–	53	152
Ds6.35x2.54	●	●	159	152
Ds6.35x5.08	●	–	125	152
Ds6.35x12.7	●	–	62	152
Ds6.35x25.4	●	–	69	152
Ds8x10	●	●	203	507
Ds8x15	●	●	203	507
Ds8x24	●	–	173	432.5
Ds10x3	●	–	410	1,025
Ds10x12	●	●	271	677
Ds10x25	●	●	249	623
Ds10x50	●	●	144	361
Ds12x5	●	–	407	1,018
Ds12.7x12.7	●	–	427	1,067.5
Ds12x15	●	–	659	1,031
Ds12x25	●	–	291	1,018
Ds14x25	●	●	408	1,019
Ds14x30	●	–	408	1,019
Ds16x35	●	–	477	1,192
Ds18x24	●	●	573	1,431
Ds18x40	●	●	546	1,365

Order key

Type d2 b1 Thread

DST - J S □ M - C - 01 - DS 10X12

dryspin® technology	iglidur® material	Form S	Hand of rotation	Metric	Thread: cut	Type	Thread type	Diameter [mm]	Pitch
---------------------	-------------------	--------	------------------	--------	-------------	------	-------------	---------------	-------

Options:
Hand of rotation
R: Right-hand thread
L: Left-hand thread

J High efficiency at all speeds
E7 For high speeds

Dimensions [mm]

d1 ¹⁵⁶⁾	d2 ¹⁵⁶⁾	A	b1 ¹⁵⁶⁾	Weight [g]	Part No.
4	12	11	12	1.46	DST-JSRM-C-01-DS4X2.4 New
5	12	11	12	1.46	DST-JSRM-C-01-DS5X5 New
6.35	12	11	12	1.46	DST-JS□M-C-01-DS6.35X2.54
6.35	12	11	12	1.46	DST-JSRM-C-01-DS6.35X5.08
6.35	12	11	12	1.46	DST-JSRM-C-01-DS6.35X12.7
6.35	12	11	12	1.46	DST-JSRM-C-01-DS6.35X25.4
8	20	18	20	7.86	DST-JS□M-C-01-DS8X10
8	20	19	20	7.86	DST-JS□M-C-01-DS8X15
8	20	18	20	7.90	DST-JSRM-C-01-DS8X24 New
10	20	18	20	7.02	DST-JSRM-C-01-DS10X3 New
10	20	18	20	7.02	DST-JS□M-C-01-DS10X12
10	20	18	20	7.02	DST-JS□M-C-01-DS10X25
10	20	18	20	7.02	DST-JS□M-C-01-DS10X50
12	24	22.6	25	12.64	DST-JSRM-C-01-DS12X5
12	24	22.6	25	12.64	DST-JSRM-C-01-DS12.7X12.7 New
12	24	22.6	25	12.60	DST-JSRM-C-01-DS12X15 New
12	26	22.6	25	12.64	DST-JSRM-C-01-DS12X25
14	24	22.6	25	11.12	DST-JS□M-C-01-DS14X25
14	24	22.6	25	11.12	DST-JSRM-C-01-DS14X30
16	28	26.2	25	15.45	DST-JSRM-C-01-DS16X35
18	28	26.2	25	13.46	DST-JS□M-C-01-DS18X24
18	28	26.2	25	13.46	DST-JS□M-C-01-DS18X40

¹⁵⁶⁾ Tolerances according to DIN ISO 2768-1, tolerance class m (medium)

Technical data

Thread	Hand of rotation		Effective supporting surface [mm ²]	Max. stat. axial F [N]
	right	left		
Ds6.35x2.54	●	●	159	79.5
Ds6.35x5.08	●	–	125	62.5
Ds6.35x12.7	●	–	62	31.0
Ds6.35x25.4	●	–	69	34.5
Ds8x10	●	–	203	101.5
Ds8x15	●	–	203	101.5
Ds10x12	●	–	217	108.5
Ds10x25	●	–	249	124.5
Ds10x50	●	–	144	72.0
Ds12x5	●	–	407	203.5
Ds12x25	●	–	291	145.5
Ds14x25	●	–	408	204.0
Ds14x30	●	–	408	204.0

Dimensions [mm]

d1 ¹⁵⁶⁾	d2 ¹⁵⁶⁾	A	b1 ¹⁵⁶⁾	Weight [g]	Part No.
6.35	12	11	12	1.20	DST-E7S□M-C-01-DS6.35X2.54 New
6.35	12	11	12	1.20	DST-E7SRM-C-01-DS6.35X5.08 New
6.35	12	11	12	1.20	DST-E7SRM-C-01-DS6.35X12.7 New
6.35	12	11	12	1.20	DST-E7SRM-C-01-DS6.35X25.4 New
8	20	18	20	5.00	DST-E7SRM-C-01-DS8X10 New
8	20	18	20	5.00	DST-E7SRM-C-01-DS8X15 New
10	20	18	20	5.00	DST-E7SRM-C-01-DS10X12 New
10	20	18	20	5.00	DST-E7SRM-C-01-DS10X25 New
10	20	18	20	5.00	DST-E7SRM-C-01-DS10X50 New
12	24	22.6	25	9.80	DST-E7SRM-C-01-DS12X5 New
12	26	22.6	25	9.80	DST-E7SRM-C-01-DS12X25 New
14	24	22.6	25	9.80	DST-E7SRM-C-01-DS14X25 New
14	24	22.6	25	9.80	DST-E7SRM-C-01-DS14X30 New

¹⁵⁶⁾ Tolerances according to DIN ISO 2768-1, tolerance class m (medium)

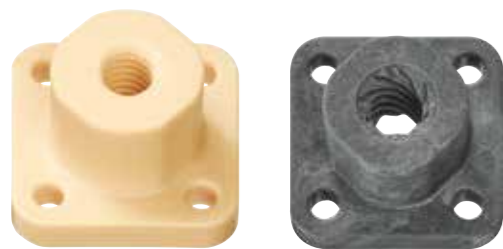

Images exemplary

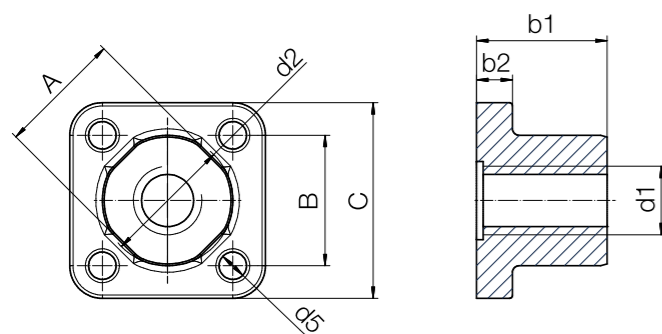

Technical data

Thread	Hand of rotation		Effective supporting surface [mm²]	Max. stat. axial F [N]
	right	left		
Ds5x5	●	–	53	152
Ds6.35x2.54	●	●	199	125
Ds6.35x5.08	●	–	156	125
Ds6.35x12.7	●	–	78	125
Ds6.35x25.4	●	–	86	125
Ds8x10	●	●	203	507
Ds8x15	●	●	254	634
Ds8x24	●	–	173	432.5
Ds10x3	●	–	410	1,025
Ds10x12	●	●	338	846
Ds10x25	●	●	312	779
Ds10x50	●	●	181	451
Ds12x5	●	–	570	1,425
Ds12.7x12.7	●	–	427	1,067.5
Ds12x15	●	–	659	1,031
Ds12x25	●	–	548	1,425
Ds14x25	●	●	571	1,427
Ds14x30	●	–	571	1,427
Ds16x35	●	–	668	1,669
Ds18x24	●	●	802	2,004
Ds18x40	●	●	764	1,911

Order key

Type d2 b1 Thread

DST - J F □ M - C - 01 - DS 10X12

Options:
Hand of rotation
R: Right-hand thread
L: Left-hand thread

dryspin® technology
iglidur® material
Form F
Hand of rotation
Metric
Thread: cut
Type
Thread type
Diameter [mm]
Pitch

J High efficiency at all speeds
E7 For high speeds

Dimensions [mm]

d1 ¹⁵⁶⁾	d2 ¹⁵⁶⁾	A	B	C	d5	b1 ¹⁵⁶⁾	b2	Weight [g]	Part No.
5.0	14	11	12	18	3.2	12	4	2.71	DST-JFRM-C-01-DS5X5 New
6.35	12	11	12	18	3.2	12	4	2.71	DST-JF□M-C-01-DS6.35X2.54
6.35	12	11	12	18	3.2	12	4	2.71	DST-JFRM-C-01-DS6.35X5.08
6.35	12	11	12	18	3.2	12	4	2.71	DST-JFRM-C-01-DS6.35X12.7
6.35	12	11	12	18	3.2	12	4	2.71	DST-JFRM-C-01-DS6.35X25.4
8	20	19	20	30	4.2	20	5.5	12.66	DST-JF□M-C-01-DS8X10
8	20	19	20	30	4.2	20	5.5	12.66	DST-JF□M-C-01-DS8X15
8	20	19	20	30	4.2	20	5.5	12.60	DST-JFRM-C-01-DS8X24 New
10	20	19	20	30	4.2	20	5.5	11.82	DST-JFRM-C-01-DS10X3 New
10	20	19	20	30	4.2	20	5.5	11.82	DST-JF□M-C-01-DS10X12
10	20	19	20	30	4.2	20	5.5	11.82	DST-JF□M-C-01-DS10X25
10	20	19	20	30	4.2	20	5.5	11.82	DST-JF□M-C-01-DS10X50
12	24	22.6	24	34	5	25	6	18.93	DST-JFRM-C-01-DS12X5
12	24	22.6	24	34	5	25	6	18.93	DST-JFRM-C-01-DS12.7X12.7 New
12	24	22.6	24	34	5	25	6	19.00	DST-JFRM-C-01-DS12X15 New
12	24	22.6	24	34	5	25	6	18.93	DST-JFRM-C-01-DS12X25
14	24	22.6	24	34	5	25	6	17.41	DST-JF□M-C-01-DS14X25
14	24	22.6	24	34	5	25	6	17.41	DST-JFRM-C-01-DS14X30
16	28	25.5	27	38	6	25	6.5	22.85	DST-JFRM-C-01-DS16X35
18	28	25.5	27	38	6	25	6.5	21.48	DST-JF□M-C-01-DS18X24
18	28	25.5	27	38	6	25	6.5	21.48	DST-JF□M-C-01-DS18X40

¹⁵⁶⁾ Tolerances according to DIN ISO 2768-1, tolerance class m (medium)

Technical data

Thread	Hand of rotation		Effective supporting surface [mm ²]	Max. stat. axial F [N]
	right	left		
Ds6.35x2.54	●	●	199	80
Ds6.35x5.08	●	–	156	63
Ds6.35x12.7	●	–	78	31
Ds6.35x25.4	●	–	86	35
Ds8x10	●	●	203	102
Ds8x15	●	●	254	102
Ds10x12	●	●	338	136
Ds10x25	●	●	312	125
Ds10x50	●	●	181	72

Dimensions [mm]

d1 ¹⁵⁶⁾	d2 ¹⁵⁶⁾	A	B	C	d5	b1 ¹⁵⁶⁾	b2	Weight [g]	Part No.
6.35	12	11	12	18	3.2	12	4	1.9	DST-E7F□M-C-01-DS6.35X2.54
6.35	12	11	12	18	3.2	12	4	1.9	DST-E7FRM-C-01-DS6.35X5.08
6.35	12	11	12	18	3.2	12	4	1.9	DST-E7FRM-C-01-DS6.35X12.7
6.35	12	11	12	18	3.2	12	4	1.9	DST-E7FRM-C-01-DS6.35X25.4
8	20	19	20	30	4.2	20	5.5	9.0	DST-E7F□M-C-01-DS8X10
8	20	19	20	30	4.2	20	5.5	9.0	DST-E7F□M-C-01-DS8X15
10	20	19	20	30	4.2	20	5.5	9.0	DST-E7F□M-C-01-DS10X12
10	20	19	20	30	4.2	20	5.5	9.0	DST-E7F□M-C-01-DS10X25
10	20	19	20	30	4.2	20	5.5	9.0	DST-E7F□M-C-01-DS10X50

¹⁵⁶⁾ Tolerances according to DIN ISO 2768-1, tolerance class m (medium)

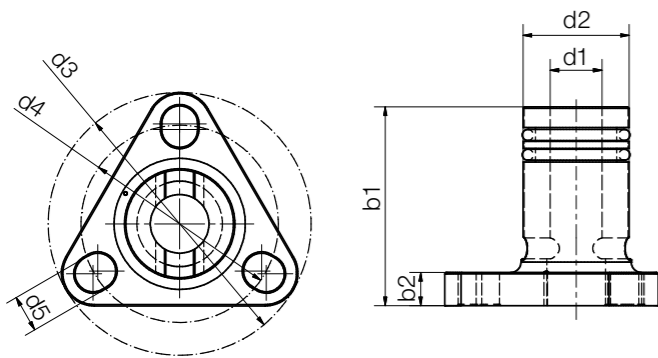

Technical data

Thread	Max. stat. axial F [N]	Max. idling torque (with O-ring) from [Nm]	Weight [g]
Ds6.35x2.54	40	0.005	3.8
Ds6.35x5.08	40	0.005	3.8
Ds6.35x12.7	40	0.005	3.8
Ds6.35x25.4	40	0.005	3.8
Ds8x10	75	0.01	12.1
Ds8x15	75	0.01	12.1
Ds10x12	75	0.01	12.1
Ds10x25	75	0.01	12.1
Ds10x50	75	0.01	12.1
Ds12x5	125	0.03	18.0
Ds12x25	125	0.03	18.0
Ds14x25	125	0.03	18.0
Ds14x30	125	0.03	18.0
Ds14x40.6	125	0.03	18.0

 Order key

Part number	Type	Thread
DST- J F R M-LC-0001-DS 10X12		
dryspin® technology	iglidur® J	
	Form F	
	Hand of rotation	
	Metric	
	Low Clearance	
	Type 0001	
	Thread type	
	Thread Ø [mm]	
	Pitch	

Dimensions [mm]

d1 ¹⁵⁶⁾	d2 ¹⁵⁶⁾	d3	d4	d5	b1 ¹⁵⁶⁾	b2	Part No.
6.35	10	285	22.2	3.7	25.0	4.1	DST-JFRM-LC-0001-DS6.35X2.54
6.35	10	285	22.2	3.7	25.0	4.1	DST-JFRM-LC-0001-DS6.35X5.08
6.35	10	285	22.2	3.7	25.0	4.1	DST-JFRM-LC-0001-DS6.35X12.7
6.35	10	285	22.2	3.7	25.0	4.1	DST-JFRM-LC-0001-DS6.35X25.4
8	16	38.1	28.3	5.2	28.8	4.8	DST-JFRM-LC-0001-DS8X10
8	16	38.1	28.3	5.2	28.8	4.8	DST-JFRM-LC-0001-DS8X15
10	16	38.1	28.3	5.2	28.3	4.8	DST-JFRM-LC-0001-DS10X12
10	16	38.1	28.3	5.2	28.3	4.8	DST-JFRM-LC-0001-DS10X25
10	16	38.1	28.3	5.2	28.3	4.8	DST-JFRM-LC-0001-DS10X50
12	20	41.1	31.8	5.2	44.0	7.0	DST-JFRM-LC-0001-DS12X5
12	20	41.1	31.8	5.2	44.0	7.0	DST-JFRM-LC-0001-DS12X25
14	20	41.1	31.8	5.2	44.0	7.0	DST-JFRM-LC-0001-DS14X25
14	20	41.1	31.8	5.2	44.0	7.0	DST-JFRM-LC-0001-DS14X30
14	20	41.1	31.8	5.2	44.0	7.0	DST-JFRM-LC-0001-DS14X40.6

¹⁵⁶⁾ Tolerances according to DIN ISO 2768-1, tolerance class m (medium)

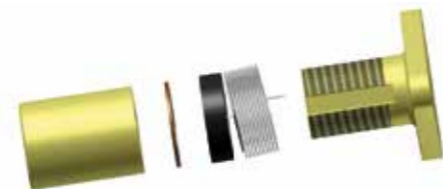
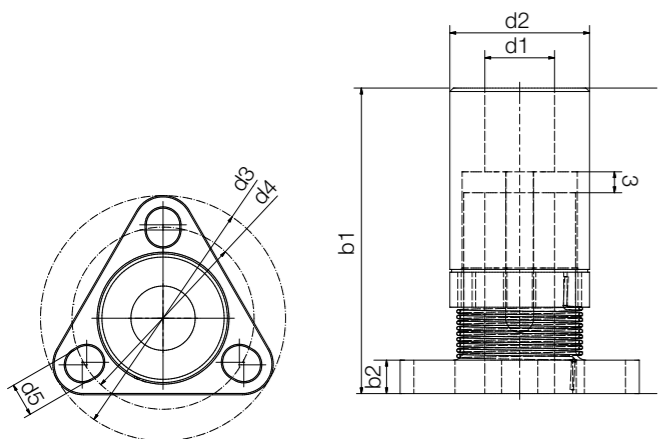

 Installation instructions and video tutorials
▶ www.igus.eu/zero-backlash-nut

Technical data

Thread	Max. stat. axial F [N]	Max. idling torque (with spring) ¹⁷⁰⁾ from [Nm]	Weight [g]
Ds5x5	75	0.02	5.1
Ds6.35x2.54	75	0.02	5.1
Ds6.35x5.08	75	0.02	5.1
Ds6.35x12.7	75	0.02	5.1
Ds6.35x25.4	75	0.02	5.1
Ds8x10	150	0.03	15.2
Ds8x15	150	0.03	15.2
Ds8x24	150	0.03	15.2
Ds10x12	150	0.04	15.2
Ds10x25	150	0.04	15.2
Ds10x50	150	0.04	15.2

¹⁷⁰⁾ The idling torque of the zero-backlash lead screw nut increases with service life. When calculating the dimensions, it is recommended that the maximum idling torque be taken into account.

 Order key

Part number	Type	Thread
DST- J F R M-ZB-0001-DS 10X12		
dryspin® technology	iglidur® J	Type 0001
	Form F	Thread type
	Hand of rotation	Thread Ø [mm]
	Metric	Pitch
	Zero-backlash	

Dimensions [mm]

d1 ¹⁵⁶⁾	d2 ¹⁵⁶⁾	d3	d4	d5	b1 ^{40) 156)}	b2	Part No.
5	13.5	28	22.2	3.7	31 – 36	4.1	DST-JFRM-ZB-0001-DS5X5 New
6.35	13.5	28	22.2	3.7	31 – 36	4.1	DST-JFRM-ZB-0001-DS6.35X2.54
6.35	13.5	28	22.2	3.7	31 – 36	4.1	DST-JFRM-ZB-0001-DS6.35X5.08
6.35	13.5	28	22.2	3.7	31 – 36	4.1	DST-JFRM-ZB-0001-DS6.35X12.7
6.35	13.5	28	22.2	3.7	31 – 36	4.1	DST-JFRM-ZB-0001-DS6.35X25.4
8	20	38.1	28.3	5.2	41 – 47	4.8	DST-JFRM-ZB-0001-DS8X10
8	20	38.1	28.3	5.2	41 – 47	4.8	DST-JFRM-ZB-0001-DS8X15
8	20	38.1	28.3	5.2	41 – 47	4.8	DST-JFRM-ZB-0001-DS8X24 New
10	20	38.1	28.3	5.2	41 – 47	4.8	DST-JFRM-ZB-0001-DS10X12
10	20	38.1	28.3	5.2	41 – 47	4.8	DST-JFRM-ZB-0001-DS10X25
10	20	38.1	28.3	5.2	41 – 47	4.8	DST-JFRM-ZB-0001-DS10X50

⁴⁰⁾ Variable according to thread pitch / clearance

¹⁵⁶⁾ Tolerances according to DIN ISO 2768-1, tolerance class m (medium)

igus® offers a large modular kit for dryspin® lead screw drives. Bearing housing for lead screws and lead screw nuts enable the design of a custom linear system. With drylin® E lead screw motors, dryspin® combines the highest precision with a longer service life.



Lead screw nut housings

- Universal support for dryspin® lead screw nut with flange
 - Material: anodised aluminium
 - Available individually or completely pre-assembled
- Page 1340



Lead screw support blocks

- Lead screw support block including clamping rings and lubrication-free plain bearings
 - Material: anodised aluminium
 - Fixed and floating bearing version available
- Page 1342



drylin® E lead screw motor with dryspin® technology

- NEMA 11/17/23 stepper motors
 - Direct centring of the dryspin® lead screw for highest precision
 - Many combination options
- Page 1447



Special components

- Special machined lead screw which can be configured online
- Custom machining nuts/lead screw upon request



drylin® lead screw technology – Trapezoidal and metric threads

Self-locking

Maintenance-free dry operation

Resistant to dirt and long service life

Lead screw nuts made from lubrication-free **dry-tech®** polymers

Lead screws made from steel, stainless steel or aluminium

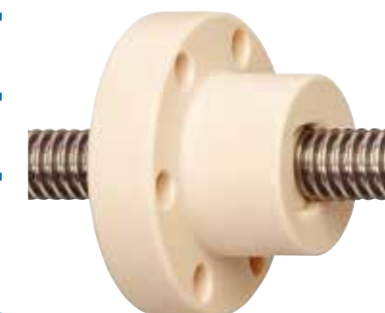

Radial loads

drylin® lead screw nuts are designed to absorb axial forces. Any radial forces that may occur in the application should be absorbed by additional linear guides. ► **drylin® linear technology, from page 941**

Temperature

drylin® lead screw nuts, which are manufactured from maintenance-free iglidur® materials, are suited for use in temperatures ranging from -20°C to +90°C (+150°C, depending on material). Please note that the temperature also has an effect on the clearance of the nut, as well as the maximum load capacity. When the application is exposed to temperature and load extremes, we recommend testing the suitability of the lead screw nuts in this specific case by a practical test. In order to provide for the use in all temperature ranges, we have lead screw nuts available in various clearance classes.

Wet environments

Trapezoidal lead screw nuts made from iglidur® J or iglidur® A180 must be used for applications in humid environments, especially for wet applications. These materials are characterised by very low moisture absorption. ► **igidur® J, page 159** and ► **igidur® A180, page 401**

Dirt

With the use of the maintenance-free iglidur® materials for lead screw nut production, drylin® lead screw drives feature completely dry operation. Due to the deliberate avoidance of lubricants, the adhesion of soft particles such as dust and fibres is reduced. When compared to conventional, lubricated materials, it is common to see significant improvements in the service life in contaminated environments. However, in environments with significant contamination and hard particles, such as metal swarf or granite dust, the lead screw should be covered.

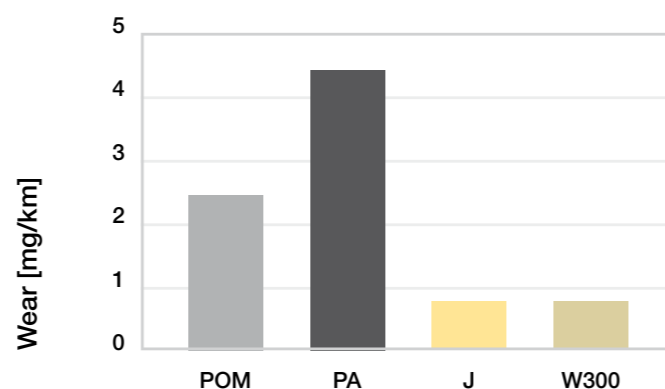

Diagram 01: Wear test on a rolled trapezoidal lead screw

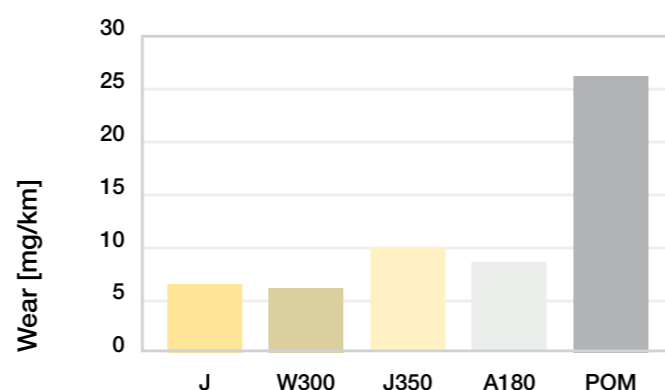

Diagram 02: Wear test on a C15 lead screw
Stroke 140mm, 50N, lead screw C15 rolled, 450rpm

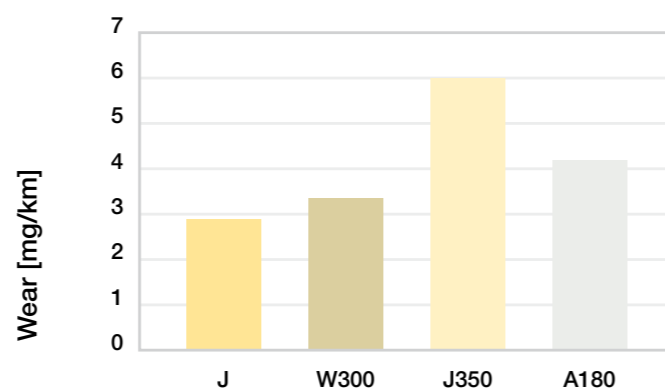

Diagram 03: Wear test on a VA lead screw
Stroke 140mm, 50N, lead screw VA rolled, 450rpm

Lead screw drive inspection

drylin® lead screw drives are manufactured in accordance with DIN 103. Inspection is performed with standard thread plug gauges after production. The DIN 103 standard is converted to the corresponding size for any thread sizes that are not shown in the standard table. The hygroscopic and thermal properties of the material must be taken into account during selection. Dimensional changes can occur as a result of moisture and/or thermal exposure at the point of use. For these reasons, general DIN compatibility cannot be guaranteed.

Noise

Noise can generally occur with the use of lead screw drives. In particular, long lead screws and long travel distances can cause self-induced vibrations in the systems. Due to their good sliding properties, lead screw nuts made from the tribologically optimised iglidur® materials tend to develop less noise than conventional plastics or metallic materials, such as bronze or brass. If your lead screw drive develops noise, please contact us to discuss this with our experts.

► **Anti-backlash lead screw nut, page 1324**

Clearance

The reliable operation of lead screw drives requires a basic amount of clearance. Application-specific parameters must be observed in addition to the lead screw drive clearance caused by manufacturing tolerances. In addition to thermal and hygroscopic environmental influences, the minimum clearance to be accounted for in the application must also take into account the friction heat generated by the application. The use of lead screw drives is therefore not recommended for precision drives without conducting practical tests. In practice, pre-load has proven to be an effective counter-measure for undesirable clearance. In addition to the solutions from our standard product range, our technical support team will be pleased to discuss other options.

Levels of efficiency

Efficiency is the ratio between the output and input power rating. drylin® lead screw nuts are characterised by a low coefficient of friction, resulting in high efficiencies. Single start trapezoidal lead screw nuts achieve efficiencies between 20 and 48% in dry operation. High helix lead screw nuts achieve efficiencies between 50 and 80% in dry operation. Even though drylin® lead screw nuts were developed for completely dry operation, lubrication can help to additionally increase efficiency.

Self-locking

Single start trapezoidal lead screw drives are self-locking. This means that the flank angle and the sliding friction prevent movement of the nut or the lead screw without the application of outside forces. As soon as the static friction is exceeded, the components are no longer self-locking. Multi start trapezoidal screw systems have a "residual self-locking" feature; high helix screw drives have no self-locking feature.

Anti-backlash lead screw nuts

Backlash is the phenomenon created on the lead screw drives by the axial clearance. By adding a radial pre-load, vibrations are significantly reduced.



Anti-backlash lead screw nuts in a glue application system of a seam gluing machine (wood industry). These ensure the utmost precision for this clearance-free adjustment drive.



Format adjustment in the paper industry with anti-backlash lead screw nut

Zero-backlash lead screw nuts

Lead screw drives with high helix thread for quick adjustments of small loads. The zero-backlash principle provides for minimal backlash for the life of the product. Ideal for precise positioning and feed movements in medical, laboratory and printing systems and other life science fields. High helix lead screw nuts without zero-backlash feature or trapezoidal threads should be used for high loads, dirt accumulation or extreme external influences.

Installation of lead screw nuts

drylin® lead screw nuts must be secured against twisting and sag.

Lead screw nuts with flange

The maximum tightening torque for the assembly of lead screw nuts with flange is 2.5Nm. We recommend that assembly screws are secured with a semi-permanent thread locking glue. Metallic ferrules should be used for even higher tightening torques.

Cylindrical lead screw nuts

The outer diameter of cylindrical lead screw nuts is not designed for a press fit. We therefore recommend the use of spanner flats. In practice, a screw mount has proven to be effective with low forces. Gluing lead screws nuts is not recommended. If however, the securing of the lead screw nuts by adhesives is planned, individual tests are necessary in each case.

Lead screw selection

The suitability and the operating behaviour of the system largely depend on the lead screws used with the nut. We recommend purchasing the nut and lead screw as a system from a single source. Lead screws are inspected with DIN 103-compliant gauges. In principle, drylin® lead screw drives can be used with lead screws made from steel, stainless steel or hard-anodised aluminium. "Split" lead screws (right and left-handed threads on one lead screw) are available in addition to right-hand and left-hand versions.

Custom lead screws

Take advantage of our machining service - we manufacture ready-to-fit lead screws based on your requirements. Please send us your drawing. We can then provide a quotation quickly.



Custom lead screw example

Custom nuts

Take advantage of our machining service – we manufacture ready-to-fit lead screw nuts based on your requirements. Please send us your drawing. We can then provide a quotation quickly.



Custom nut examples

Material selection

drylin® lead screw nuts are supplied in 7 standard materials:

High efficiency at all speeds:

iglidur® J ► Page 159

- High speed
- Low wear
- Best coefficient of friction

For heavy duty applications up to 5MPa:

iglidur® W300 ► Page 171

- High static strength

For temperatures up to +150°C:

iglidur® J350 ► Page 199

- For high temperatures
- Good coefficient of friction with medium loads

For medium to high speeds:

iglidur® R ► Page 247

- High wear resistance for low loads
- Low moisture absorption
- Vibration-dampening

FDA-compliant for the food and pharmaceutical industry:

iglidur® A180 ► Page 401

- FDA-compliant
- For contact with food

Best running partner for hard anodised aluminium:

iglidur® J200 ► Page 261

- Low coefficient of friction and wear
- Long service life

For high speeds:

iglidur® E7 ► Page 267

- Low loads up to 200N
- Speeds up to 1,200rpm

Service life

drylin® lead screw nuts are made from tribologically optimised materials. Already during the development phase, the focus is on optimising the friction properties of the drylin® lead screw drives, with the objective of attaining the lowest possible coefficient of wear and friction. In order to make the most precise statements about service life and wear resistance, several hundred tests are conducted each year on the test equipment at the igus® test lab in Cologne. Our experts will gladly test your application as well.

iglidur® material	Max. surface pressure [MPa]
iglidur® J	4.0
iglidur® W300	5.0
iglidur® J350	3.0
iglidur® R	2.0
iglidur® A180	3.5
iglidur® E7	0.5
iglidur® J200	2.0

Table 01: Permitted continuous surface pressure in the threads

Correct choice of material

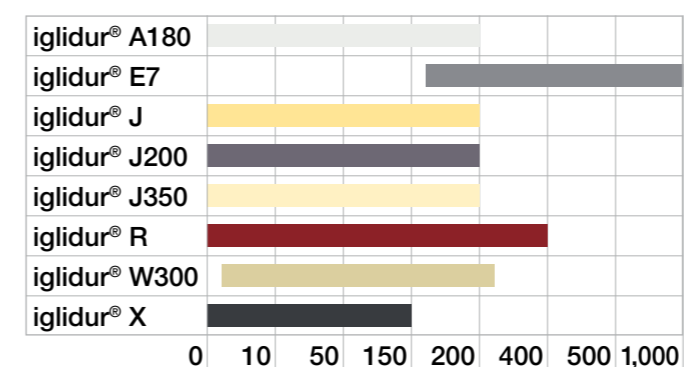

Speed [rpm]

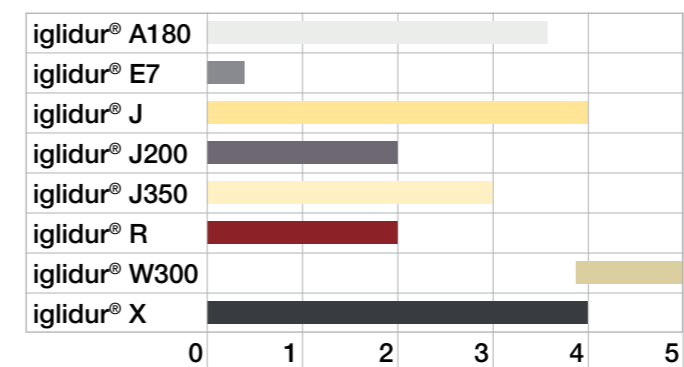

Surface pressure in thread [MPa]

iglidur® X not available in combination with dryspin® high helix thread, iglidur® J200 only available in combination with aluminium

Tightening torque for drylin® connections between metal parts

Metric thread (Da)	Tightening torque [Nm]	Recommended tightening torque [Nm]
M3	0.5–1.1	0.7
M4	1.0–2.8	1.5
M5	2.0–5.5	3.0
M6	4.0–10.0	6.0
M8	8.0–23.0	15.0
M10	22.0–46.0	30.0

Please be aware of the minimal screw-in depth for aluminium and zinc parts: 1.5xDa

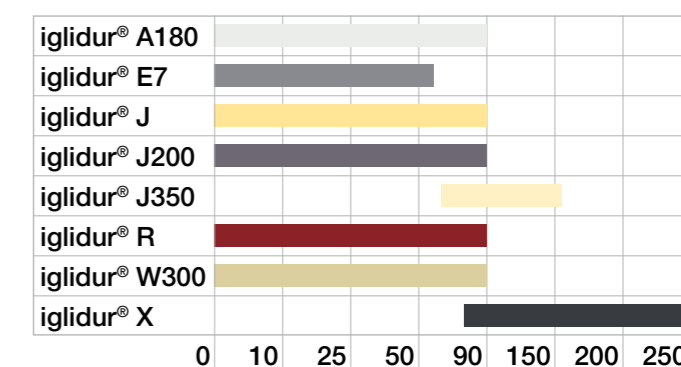

Temperature [°C]

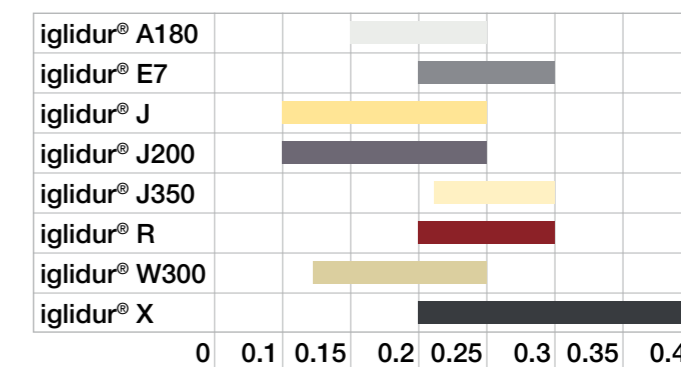

Coefficient of friction [μ]

Required drive torque

The required drive torque of the lead screw nut is obtained from the axial load, the lead screw pitch, the coefficient of surface friction of the lead screw drive and the lead screw support. At high speeds, the acceleration torque must be taken into account, which may cause increased breakaway torque depending on the installation. Dirt, dust and the surface or the condition of the lead screw can increase the drive torque. However, lubrication can temporarily reduce the required drive forces.

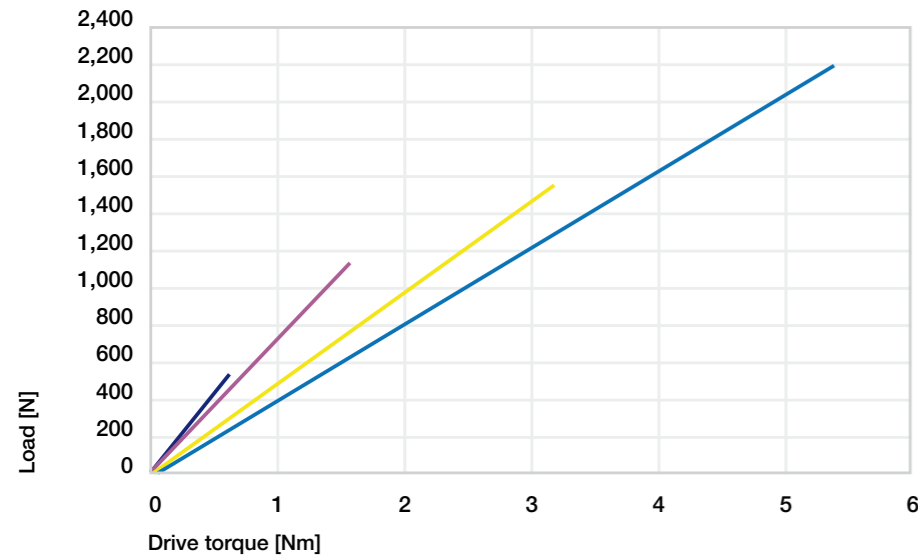

- Tr8x1,5
- Tr10x2
- Tr12x3
- Tr14x4

Diagram 06:
Required drive torque of lead screw drives Ø8 to Ø14 – assuming $\mu = 0.25$, without considering the lead screw support

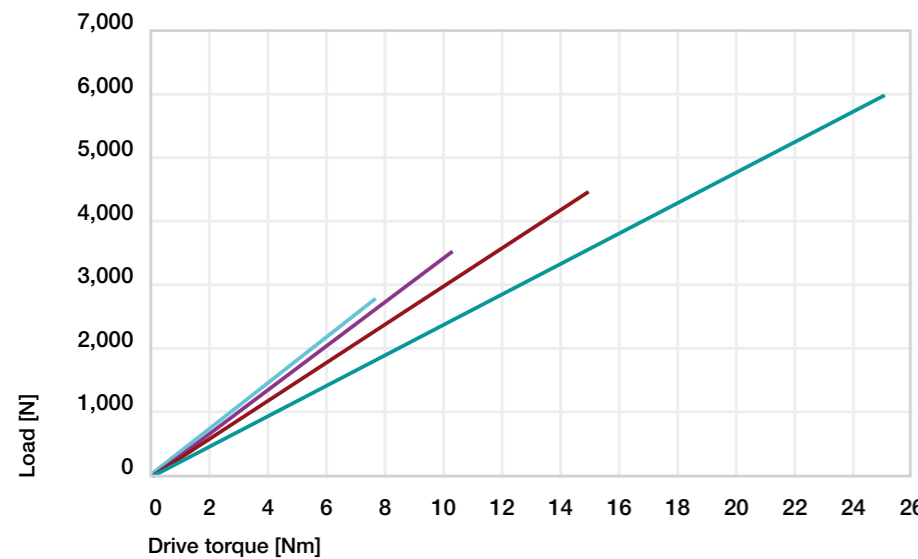

- Tr16x4
- Tr18x4
- Tr20x4
- Tr24x5

Diagram 07:
Required drive torque of lead screw drives Ø16 to Ø24 – assuming $\mu = 0.25$, without considering the lead screw support

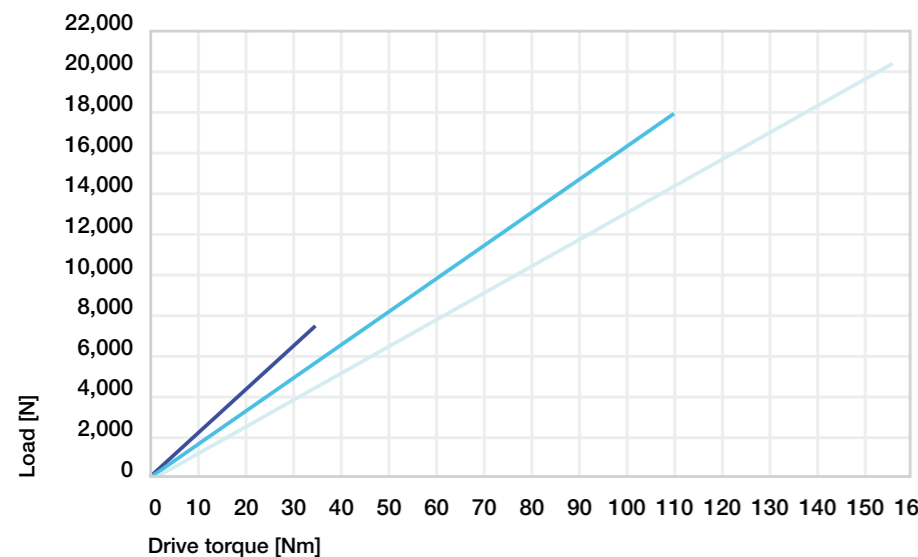

- Tr30x6
- Tr40x7
- Tr50x8

Diagram 08:
Required drive torque of lead screw drives Ø30 to Ø50 – assuming $\mu = 0.25$, without considering the lead screw support

Max. permissible pv value

With the pv value and the effective support surface stated in the dimensions tables, the permissible sliding speed and from it the feed rate for each thread size can be determined.

Operating time (ESD)	pv value _{max.} [MPa · m/s]	(applicable for iglidur® J, W300, A180, R and J350)
100%	0.08	
50%	0.2	
10%	0.4	

Table 03: Standard values when using drylin® plastic nuts without lubrication (with 500mm stroke). A correction factor must be reckoned for very short or long strokes.

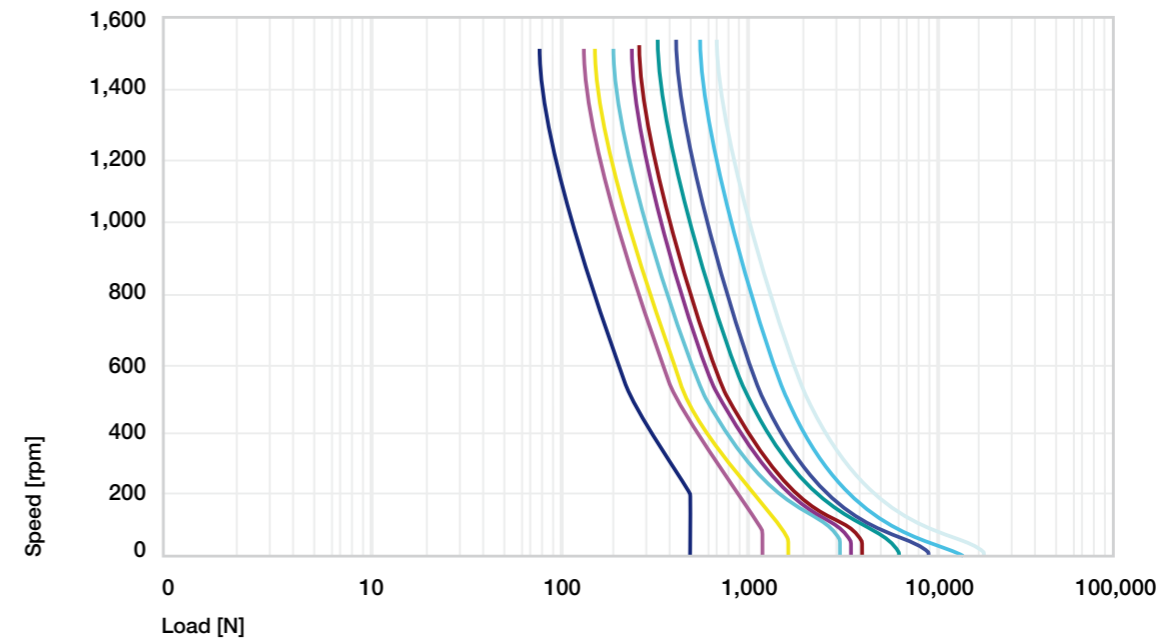

Diagram 09: Maximum dynamic load for lead screw drives with 10% ESD

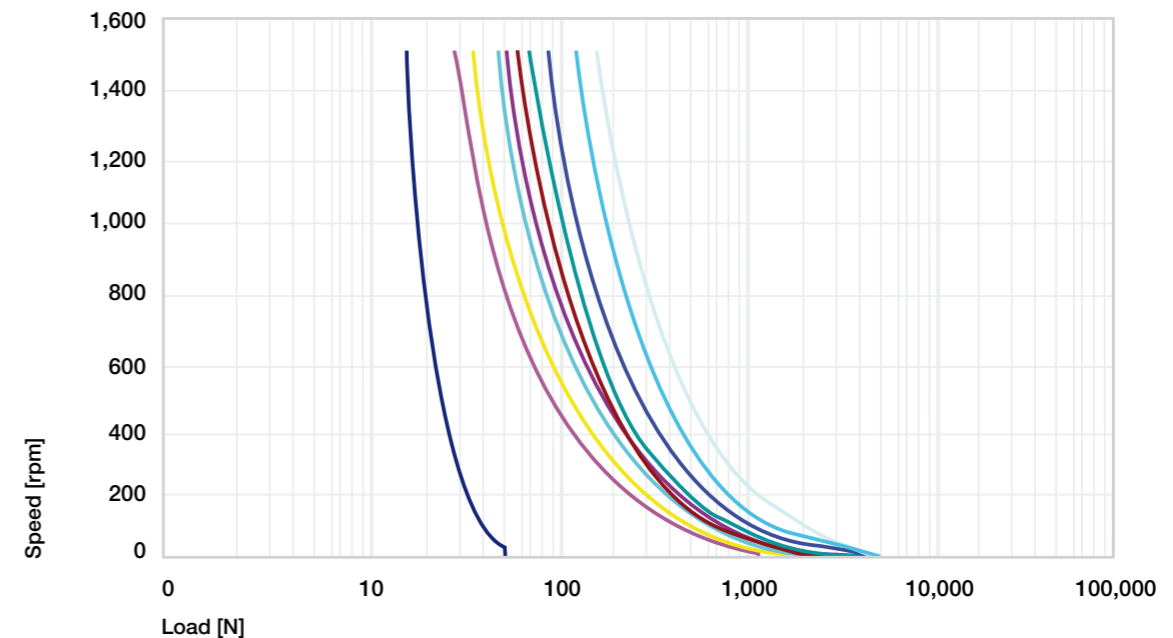

Diagram 10: Maximum dynamic load for lead screw drives with 100% ESD

- Tr8x1,5
- Tr10x2
- Tr12x3
- Tr16x4
- Tr18x4
- Tr20x4
- Tr24x5
- Tr30x6
- Tr40x7
- Tr50x8



CF15, rolled, AISI 1015



Stainless steel, rolled, AISI 304



Aluminium, rolled (EN AW 6082)



Technical data

Pitch variation	0.1mm to 300mm
Straightness (standard)	0.3mm to 300mm
Aligned	<0.1mm to 300mm
Tolerance (according to DIN 103)	7e

The tensile/compressive strength of the EN AW 6082 lead screw material is 160MPa per mm² (elongation limit 0.2mm).

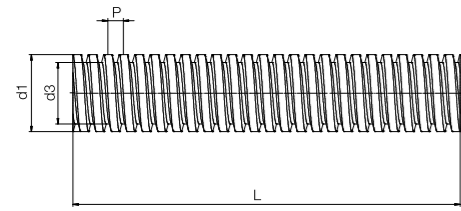

Technical data

Thread	Hand of rotation		Material						Pitch P [mm]	Pitch angle α [°]
			C15	Stainless steel				Aluminium EN AW 6082		
				Stainless steel AISI 304	Stainless steel AISI 303	Stainless steel AISI 316L	Stainless steel AISI 321			
Tr8x1.5	●	●	●	●	-	-	-	1.5	3.42	
Tr10x2	●	●	●	●	-	-	●	2	3.64	
Tr10x3	●	●	●	-	-	●	-	3	5.45	
Tr12x3	●	●	●	●	-	-	●	3	4.55	
Tr14x3	●	●	●	●	-	-	-	3	3.90	
Tr14x4	●	●	●	-	-	-	●	4	5.20	
Tr16x2	●	●	●	-	●	-	-	2	2.28	
Tr16x4	●	●	●	●	-	-	-	4	4.55	
Tr18x4	●	●	●	●	-	-	●	4	4.05	
Tr20x4	●	●	●	●	-	-	●	4	3.64	
Tr24x5	●	●	●	●	-	-	-	5	3.79	
Tr26x5	●	●	●	●	-	-	-	5	3.50	
Tr28x5	●	●	●	●	-	-	-	5	3.25	
Tr30x6	●	●	●	●	-	-	-	6	3.64	
Tr32x6	●	●	●	-	●	-	-	6	3.42	
Tr36x6	●	●	●	-	●	-	-	6	3.04	
Tr40x7	●	●	●	-	●	-	-	7	3.19	
Tr50x8	●	●	●	-	●	-	-	8	2.92	



Please contact us!

All drylin® leads screws can be custom machined. Please send us your drawing or configure online. We can then provide a quotation quickly.
 ► www.igus.eu/leadscrew-configurator



Order key

Part number	Thread	Options
-------------	--------	---------

PTGSG-10X2-01-R-1000-ES

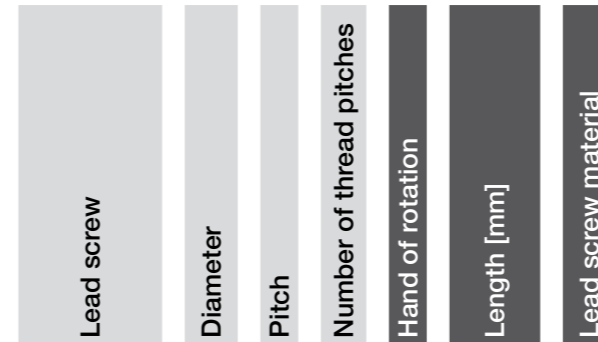

Options:
 Hand of rotation
 R: Right-hand thread
 L: Left-hand thread
 Length in mm: Freely selectable (see table)
 Lead screw material
 Blank: C15, rolled
 ES: Stainless steel, rolled
 AL: Aluminium, rolled



ACME thread (US standard)

► page 1620

Dimensions [mm]

C15	Weight		Outer Ø d1		Core Ø d3		Max. total length L			Part No.
	[kg/m]	Stainless steel [kg/m]	Aluminium [kg/m]	min.	max.	min.	max.	L		
								C15 / ES	AL	
0.39	0.40	0.14	7.8	8	5.4	6.2	1,500	-	PTGSG-8X1.5-01-□-□	
0.62	0.62	0.21	9.8	10	7.2	7.5	3,000	1,000	PTGSG-10X2-01-□-□	
0.62	0.62	0.21	9.8	10	6.2	6.5	3,000	-	PTGSG-10X3-01-□-□	
0.89	0.89	0.31	11.8	12	7.7	8.5	3,000	1,000	PTGSG-12X3-01-□-□	
1.21	1.22	0.42	13.8	14	9.7	10.5	3,000	-	PTGSG-14X3-01-□-□	
1.21	1.22	0.42	13.7	14	9.1	9.5	3,000	-	PTGSG-14X4-01-□-□	
1.58	1.59	0.54	15.8	16	11.8	12.8	3,000	-	PTGSG-16X2-01-□-□	
1.58	1.59	0.54	15.7	16	10.5	11.5	3,000	1,000	PTGSG-16X4-01-□-□	
2.00	2.01	0.69	17.7	18	12.5	13.5	3,000	2,000	PTGSG-18X4-01-□-□	
2.47	2.48	0.85	19.7	20	14.5	15.5	3,000	2,000	PTGSG-20X4-01-□-□	
3.55	3.57	1.22	23.7	24	17.3	18.5	3,000	-	PTGSG-24X5-01-□-□	
4.17	4.19	1.43	25.7	26	19.3	20.5	3,000	-	PTGSG-26X5-01-□-□	
4.83	4.86	1.66	27.7	28	21.3	22.5	3,000	-	PTGSG-28X5-01-□-□	
5.55	5.58	1.91	29.6	30	21.6	23.0	3,000	-	PTGSG-30X6-01-□-□	
6.31	6.35	2.17	31.6	32	24.5	25.0	3,000	-	PTGSG-32X6-01-□-□	
7.99	8.04	2.75	35.6	36	27.6	29.0	3,000	-	PTGSG-36X6-01-□-□	
9.86	9.93	3.39	39.6	40	30.4	32.0	3,000	-	PTGSG-40X7-01-□-□	
15.41	15.51	5.30	49.6	50	39.2	41.0	3,000	-	PTGSG-50X8-01-□-□	



The biggest online lead screw shop
 ► www.igus.eu/leadscrewshop



CF15, rolled, AISI 1015



Stainless steel, rolled, AISI 304

Technical data

Pitch variation	0.1mm to 300mm
Straightness (standard)	0.3mm to 300mm
Aligned	<0.1mm to 300mm
Tolerance (according to DIN 103)	7e

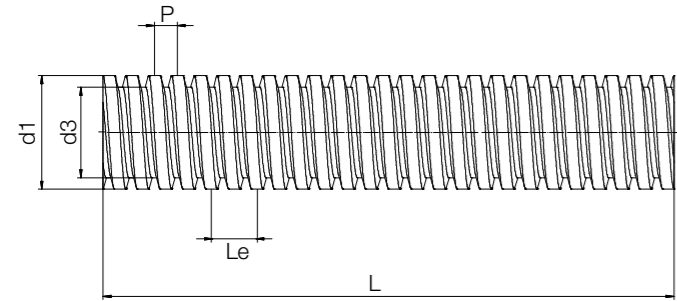

P = Pitch
Le = Lead/pitch

Technical data

Thread	Hand of rotation		Material		Total pitch Le [mm]	Pitch P [mm]	Pitch angle α [°]	Weight	
	right	left	C15	Stainless steel AISI 304				C15 [kg/m]	Stainless steel [kg/m]
Tr06x2P1	●	–	●	●	2	1	6.06	0.22	0.22
Tr10x4P2	●	●	●	●	4	2	7.26	0.62	0.62
Tr12x6P3	●	●	●	●	6	3	9.04	0.89	0.89
Tr16x8P4	●	●	●	●	8	4	9.04	1.58	1.59
Tr18x8P4	●	●	●	●	8	4	8.05	2.00	2.01
Tr20x8P4	●	●	●	●	8	4	7.26	2.47	2.48

i Definition: Multi start trapezoidal lead screw
Example 8P4 pitch

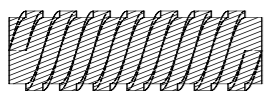

Pitch [P] = Pitch: distance to the next thread pitch, e.g. P4 = 4mm
Lead [Le] = Pitch: distance between threads flanks per thread pitch, e.g. Pitch 8 = Distance of 8mm

Order key

Part number	Thread	Options
-------------	--------	---------

PTGSG-10X4 P2-02-R-1000-ES

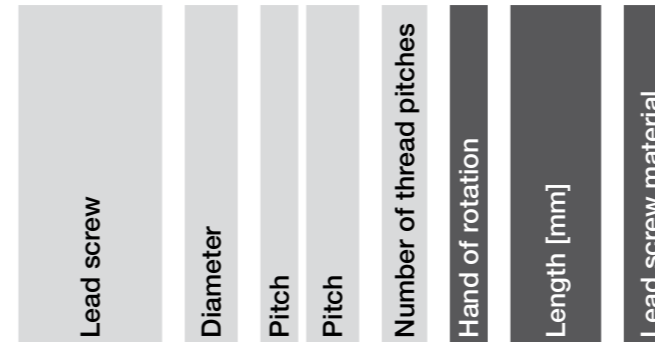

Options:
Hand of rotation
R: Right-hand thread
L: Left-hand thread
Length in mm: Freely selectable (see table)
Lead screw material
Blank: C15, rolled, AISI 1015
ES: Stainless steel, rolled, AISI 304
AL: Aluminium, rolled

Please contact us!

All drylin® leads screws can be custom machined. Please send us your drawing or configure online. We can then provide a quotation quickly.

► www.igus.eu/leadscrew-configurator

Dimensions [mm]

Outer Ø d1		Core Ø d3		Max. total length L	Part No.
min.	max.	min.	max.		
5.9	6	3.4	3.5	3,000	PTGSG-06X2P1-02-□-□
9.8	10	7.2	7.5	3,000	PTGSG-10X4P2-02-□-□
11.8	12	7.7	8.5	3,000	PTGSG-12X6P3-02-□-□
15.7	16	10.5	11.5	3,000	PTGSG-16X8P4-02-□-□
17.7	18	12.5	13.5	3,000	PTGSG-18X8P4-02-□-□
19.7	20	14.5	15.5	3,000	PTGSG-20X8P4-02-□-□

 Technical data

Pitch variation	0.1mm to 300mm
Straightness (standard)	0.3mm to 300mm
Aligned	<0.1mm to 300mm
Tolerance (according to DIN 103)	7e

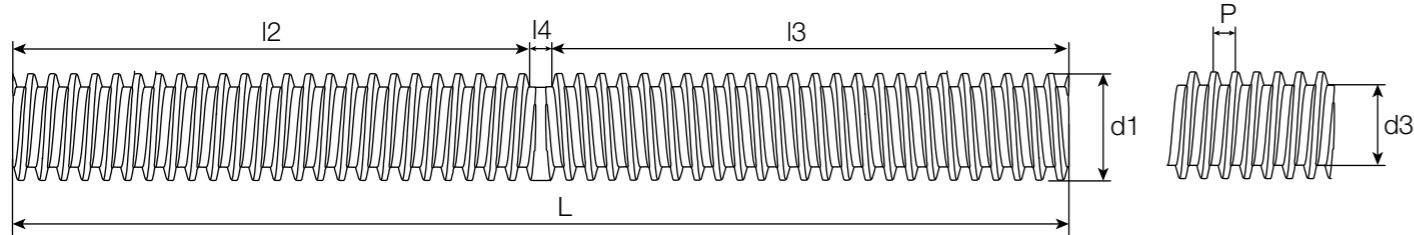

Technical data

Thread	Material		Pitch P [mm]	Pitch angle α [°]	Weight	
	C15	Stainless steel AISI 304			C15 [kg/m]	Stainless steel [kg/m]
Tr10x2	●	●	2	3.64	0.62	0.62
Tr12x3	●	●	3	4.55	0.89	0.89
Tr14x4	●	●	4	5.20	1.21	1.22
Tr16x4	●	●	4	4.55	1.58	1.58
Tr18x4	●	●	4	4.05	2.00	2.01
Tr20x4	●	●	4	3.64	2.47	2.48
Tr24x5	●	●	5	3.79	3.55	3.57

⁴⁶⁾ Non-usable thread transition

⁴⁷⁾ Length right-hand thread (I3)

⁴⁸⁾ Length left-hand thread (I2)

 Order key

Part number	Thread	Options
-------------	--------	---------

PTGSG-10X2-01-R/L-100-100-ES

Lead screw	Diameter	Pitch	Thread pitches	LH/RH	⁴⁷⁾ Length right [mm]	⁴⁸⁾ Length left-hand [mm]	Lead screw material
------------	----------	-------	----------------	-------	----------------------------------	--------------------------------------	---------------------

Options:

⁴⁷⁾ I3: Length right-hand thread

⁴⁸⁾ I2: Length left-hand thread

Length in mm: Freely selectable (see table)

Lead screw material

Blank: C15, rolled, AISI 1015

ES: Stainless steel, rolled, AISI 304

 Please contact us!

All drylin® leads screws can be custom machined. Please send us your drawing or configure online.

We can then provide a quotation quickly.

► www.igus.eu/leadscrew-configurator

Dimensions [mm]

Outer Ø d1		Core Ø d3		Thread transition I4 ⁴⁶⁾	Max. total length L	Part No.
min.	max.	min.	max.			
9.8	10	7.2	7.5	20	1,000	PTGSG-10X2-01-R/L-□ ⁴⁷⁾ -□ ⁴⁸⁾
11.8	12	7.7	8.5	30	1,000	PTGSG-12X3-01-R/L-□ ⁴⁷⁾ -□ ⁴⁸⁾ New
13.7	14	9.1	9.5	40	1,000	PTGSG-14X4-01-R/L-□ ⁴⁷⁾ -□ ⁴⁸⁾
15.7	16	10.5	11.5	30	1,000	PTGSG-16X4-01-R/L-□ ⁴⁷⁾ -□ ⁴⁸⁾ New
17.7	18	12.5	13.5	55	1,500	PTGSG-18X4-01-R/L-□ ⁴⁷⁾ -□ ⁴⁸⁾
19.7	20	14.5	15.5	55	2,000	PTGSG-20X4-01-R/L-□ ⁴⁷⁾ -□ ⁴⁸⁾
23.7	24	17.3	18.5	60	2,000	PTGSG-24X5-01-R/L-□ ⁴⁷⁾ -□ ⁴⁸⁾

Technical data

Pitch variation	0.1mm to 300mm
Straightness (standard)	0.3mm to 300mm
Aligned	<0.1mm to 300mm
Tolerance (according to DIN 13)	6g

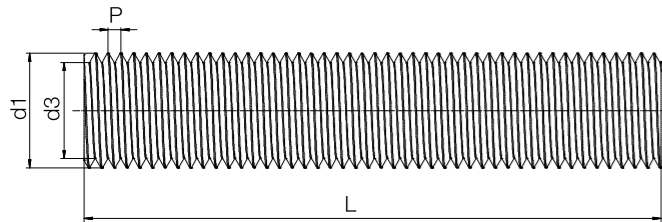
**Technical data**

Thread	Hand of rotation right	Material Stainless steel AISI 304	Pitch P [mm]	Pitch angle α [°]	Weight [kg/m]
M4	●	●	0.7	3.19	0.10
M5	●	●	0.8	2.92	0.16
M6	●	●	1.0	3.04	0.22
M8	●	●	1.25	2.85	0.40
M10	●	●	1.5	2.73	0.62

Order key

Part number	Thread	Options
-------------	--------	---------

PTGSG-M3-01-R-1000-ES

Lead screw	Thread size	Thread pitches	Hand of rotation	Length [mm]	Lead screw material
------------	-------------	----------------	------------------	-------------	---------------------

Options:

Length in mm: Freely selectable (see table)

Lead screw material

ES: Stainless steel, rolled, AISI 304

**Please contact us!**

All drylin® leads screws can be custom machined. Please send us your drawing or configure online.

We can then provide a quotation quickly.

► www.igus.eu/leadscrew-configurator

Dimensions [mm]

	Outer Ø d1		Core Ø d3		Max. total length L	Part No.
	min.	max.	min.	max.		
	2.8	3.0	2.2	2.3	1,000	PTGSG-M3-01-R-□-ES
	3.8	4.0	2.9	3.1	1,000	PTGSG-M4-01-R-□-ES
	4.8	4.9	3.8	4.0	1,000	PTGSG-M5-01-R-□-ES
	5.7	5.9	4.5	4.7	1,000	PTGSG-M6-01-R-□-ES
	7.8	8.0	6.47	6.65	1,000	PTGSG-M8-01-R-□-ES
	9.8	10.0	8.16	8.38	1,000	PTGSG-M10-01-R-□-ES

**Highly efficient at all speeds:**
iglidur® J

Thread	Efficiency	Coefficient of friction
	η	μ
Single start		
Tr8x1.5	19–37	0.1–0.25
Tr10x2	20–39	0.1–0.25
Tr10x3	27–48	0.1–0.25
Tr12x3	24–44	0.1–0.25
Tr14x3	24–40	0.1–0.25
Tr14x4	26–47	0.1–0.25
Tr16x2	14–28	0.1–0.25
Tr16x4	24–44	0.1–0.25
Tr18x4	22–41	0.1–0.25
Tr20x4	20–39	0.1–0.25
Tr24x5	21–40	0.1–0.25
Tr26x5	19–38	0.1–0.25
Tr28x5	18–36	0.1–0.25
Tr30x6	20–39	0.1–0.25
Tr32x6	19–37	0.1–0.25
Tr36x6	17–34	0.1–0.25
Tr40x7	18–36	0.1–0.25
Tr50x8	17–34	0.1–0.25
Multi start		
Tr06x2P1	29–51	0.1–0.25
Tr10x4P2	33–55	0.1–0.25
Tr12x6P3	37–60	0.1–0.25
Tr16x8P4	37–60	0.1–0.25
Tr18x8P4	35–58	0.1–0.25
Tr20x8P4	33–55	0.1–0.25
Metric		
M3	17–34	0.1–0.25
M4	18–36	0.1–0.25
M5	17–34	0.1–0.25
M6	17–34	0.1–0.25
M8	16–33	0.1–0.25
M10	16–32	0.1–0.25

**Highly resilient and wear-resistant:**
iglidur® W300

Thread	Efficiency	Coefficient of friction
	η	μ
Single start		
Tr8x1.5	19–33	0.12–0.25
Tr10x2	20–34	0.12–0.25
Tr10x3	27–44	0.12–0.25
Tr12x3	24–39	0.12–0.25
Tr14x3	21–36	0.12–0.25
Tr14x4	26–43	0.12–0.25
Tr16x2	14–25	0.12–0.25
Tr16x4	24–39	0.12–0.25
Tr18x4	22–37	0.12–0.25
Tr20x4	20–34	0.12–0.25
Tr24x5	21–35	0.12–0.25
Tr26x5	19–34	0.12–0.25
Tr28x5	18–32	0.12–0.25
Tr30x6	20–34	0.12–0.25
Tr32x6	19–33	0.12–0.25
Tr36x6	17–30	0.12–0.25
Tr40x7	18–31	0.12–0.25
Tr50x8	17–30	0.12–0.25
Multi start		
Tr06x2P1	29–46	0.12–0.25
Tr10x4P2	33–51	0.12–0.25
Tr12x6P3	37–56	0.12–0.25
Tr16x8P4	37–56	0.12–0.25
Tr18x8P4	35–53	0.12–0.25
Tr20x8P4	33–51	0.12–0.25
Metric		
M3	17–30	0.12–0.25
M4	18–31	0.12–0.25
M5	17–30	0.12–0.25
M6	17–30	0.12–0.25
M8	16–29	0.12–0.25
M10	16–28	0.12–0.25

**For temperatures up to +150°C:**
iglidur® J350

Thread	Efficiency	Coefficient of friction
	η	μ
Single start		
Tr8x1.5	19–26	0.17–0.25
Tr10x2	20–27	0.17–0.25
Tr10x3	27–35	0.17–0.25
Tr12x3	24–34	0.17–0.25
Tr14x3	21–28	0.17–0.25
Tr14x4	26–34	0.17–0.25
Tr16x2	14–19	0.17–0.25
Tr16x4	24–31	0.17–0.25
Tr18x4	22–29	0.17–0.25
Tr20x4	20–27	0.17–0.25
Tr24x5	21–28	0.17–0.25
Tr26x5	19–26	0.17–0.25
Tr28x5	18–25	0.17–0.25
Tr30x6	20–27	0.17–0.25
Tr32x6	19–26	0.17–0.25
Tr36x6	17–24	0.17–0.25
Tr40x7	18–24	0.17–0.25
Tr50x8	–	–
Multi start		
Tr06x2P1	29–38	0.17–0.25
Tr10x4P2	33–42	0.17–0.25
Tr12x6P3	37–47	0.17–0.25
Tr16x8P4	37–47	0.17–0.25
Tr18x8P4	35–44	0.17–0.25
Tr20x8P4	33–42	0.17–0.25
Metric		
M3	17–24	0.17–0.25
M4	18–24	0.17–0.25
M5	17–23	0.17–0.25
M6	17–24	0.17–0.25
M8	16–22	0.17–0.25
M10	16–22	0.17–0.25

**For medium to high speeds:**
iglidur® R

Thread	Efficiency	Coefficient of friction
	η	μ
Single start		
Tr8x1.5	16–23	0.2–0.3
Tr10x2	17–24	0.2–0.3
Tr10x3	23–32	0.2–0.3
Tr12x3	20–28	0.2–0.3
Tr14x3	18–25	0.2–0.3
Tr14x4	23–31	0.2–0.3
Tr16x2	12–16	0.2–0.3
Tr16x4	20–28	0.2–0.3
Tr18x4	19–26	0.2–0.3
Tr20x4	17–24	0.2–0.3
Tr24x5	18–25	0.2–0.3
Tr26x5	17–23	0.2–0.3
Tr28x5	16–22	0.2–0.3
Tr30x6	17–24	0.2–0.3
Tr32x6	16–23	0.2–0.3
Tr36x6	–	–
Tr40x7	–	–
Tr50x8	–	–
Multi start		
Tr06x2P1	25–34	0.2–0.3
Tr10x4P2	29–38	0.2–0.3
Tr12x6P3	33–43	0.2–0.3
Tr16x8P4	33–43	0.2–0.3
Tr18x8P4	31–40	0.2–0.3
Tr20x8P4	29–38	0.2–0.3
Metric		
M3	15–21	0.2–0.3
M4	15–22	0.2–0.3
M5	14–20	0.2–0.3
M6	15–21	0.2–0.3
M8	14–20	0.17–0.25
M10	14–19	0.17–0.25



FDA-compliant for the food/
pharmaceutical industry: iglidur® A180

Thread	Efficiency η	Coefficient of friction μ
Single start		
Tr8x1.5	19–28	0.15–0.25
Tr10x2	20–30	0.15–0.25
Tr10x3	27–38	0.15–0.25
Tr12x3	24–44	0.15–0.25
Tr14x3	21–31	0.15–0.25
Tr14x4	26–47	0.15–0.25
Tr16x2	14–21	0.15–0.25
Tr16x4	24–34	0.15–0.25
Tr18x4	22–32	0.15–0.25
Tr20x4	20–30	0.15–0.25
Tr24x5	21–30	0.15–0.25
Tr26x5	19–29	0.15–0.25
Tr28x5	18–27	0.15–0.25
Tr30x6	20–30	0.15–0.25
Tr32x6	19–28	0.15–0.25
Tr36x6	17–26	0.15–0.25
Tr40x7	18–27	0.15–0.25
Tr50x8	–	–
Multi start		
Tr06x2P1	29–41	0.15–0.25
Tr10x4P2	33–45	0.15–0.25
Tr12x6P3	37–50	0.15–0.25
Tr16x8P4	37–50	0.15–0.25
Tr18x8P4	35–48	0.15–0.25
Tr20x8P4	33–45	0.15–0.25
Metric		
M3	17–26	0.15–0.25
M4	18–27	0.15–0.25
M5	17–25	0.15–0.25
M6	17–26	0.15–0.25
M8	16–25	0.15–0.25
M10	16–24	0.15–0.25



For high speeds:
igidur® E7

Thread	Efficiency η	Coefficient of friction μ
Single start		
Tr8x1.5	16–23	0.2–0.3
Tr10x2	17–24	0.2–0.3
Tr10x3	23–32	0.2–0.3
Tr12x3	20–28	0.2–0.3
Tr14x3	18–25	0.2–0.3
Tr14x4	23–31	0.2–0.3
Tr16x2	–	–
Tr16x4	–	–
Tr18x4	–	–
Tr20x4	–	–
Tr24x5	–	–
Tr26x5	–	–
Tr28x5	–	–
Tr30x6	–	–
Tr32x6	–	–
Tr36x6	–	–
Tr40x7	–	–
Tr50x8	–	–
Multi start		
Tr06x2P1	25–34	0.2–0.3
Tr10x4P2	29–38	0.2–0.3
Tr12x6P3	33–43	0.2–0.3
Tr16x8P4	–	–
Tr18x8P4	–	–
Tr20x8P4	–	–
Metric		
M3	15–21	0.2–0.3
M4	15–22	0.2–0.3
M5	14–20	0.2–0.3
M6	15–21	0.2–0.3
M8	14–20	0.2–0.3
M10	14–19	0.2–0.3



The specialist on hard anodised
aluminium: iglidur® J200

Thread	Efficiency η	Coefficient of friction μ
Single start		
Tr8x1.5	–	–
Tr10x2	–	–
Tr10x3	–	–
Tr12x3	–	–
Tr14x3	–	–
Tr14x4	–	–
Tr16x2	–	–
Tr16x4	24–44	0.1–0.25
Tr18x4	22–41	0.1–0.25
Tr20x4	20–39	0.1–0.25
Tr24x5	21–40	0.1–0.25
Tr26x5	19–38	0.1–0.25
Tr28x5	18–36	0.1–0.25
Tr30x6	20–39	0.1–0.25
Tr32x6	19–37	0.1–0.25
Tr36x6	17–34	0.1–0.25
Tr40x7	18–36	0.1–0.25
Tr50x8	17–34	0.1–0.25
Multi start		
Tr06x2P1	29–51	0.1–0.25
Tr10x4P2	33–55	0.1–0.25
Tr12x6P3	37–60	0.1–0.25
Tr16x8P4	37–60	0.1–0.25
Tr18x8P4	35–58	0.1–0.25
Tr20x8P4	33–55	0.1–0.25
Metric		
M3	17–34	0.1–0.25
M4	18–36	0.1–0.25
M5	17–34	0.1–0.25
M6	17–34	0.1–0.25
M8	16–33	0.1–0.25
M10	–	–

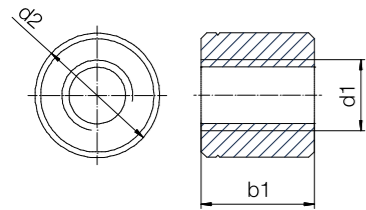

Order key

Type d2 b1 Thread

S R M-2215TR10X2

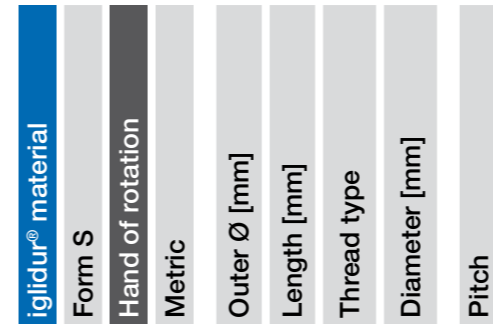

Options:
Hand of rotation
R: Right-hand thread
L: Left-hand thread

- J** High efficiency at all speeds
- W(300)** Extremely strong and wear-resistant
- J350** For temperatures up to +150°C
- R** The cost-effective option for high volume
- A180** FDA-compliant for the food and pharmaceutical industries

Technical data

Thread	Hand of rotation		Effective supporting surface [mm²]	Max. stat. axial F [N]				
	right	left		igidur®				
				J	W300	J350	R	A180
Tr8x1.5	●	●	205	500 ⁴³⁾	500 ⁴³⁾	500 ⁴³⁾	500 ⁴³⁾	500 ⁴³⁾
Tr8x1.5	●	●	137	547	683	410	273	478
Tr10x2	●	●	212	848	1,060	636	424	742
Tr10x2	●	●	283	1,131	1,414	848	565	990
Tr10x3	●	●	200	801	1,001	601	401	701
Tr10x3	●	●	267	1,068	1,335	801	534	935
Tr12x3	●	●	297	1,188	1,484	891	594	1,039
Tr12x3	●	●	396	1,583	1,979	1,188	792	1,385
Tr14x3	●	●	550	2,199	2,749	1,649	1,100	1,924
Tr14x4	●	●	396	1,583	1,979	1,188	792	1,385
Tr14x4	●	●	528	2,111	2,639	1,583	1,056	1,847
Tr16x2	●	●	565	2,262	2,827	1,696	1,131	1,979
Tr16x2	●	●	754	3,016	3,770	2,262	1,508	2,639
Tr16x4	●	●	528	2,111	2,639	1,583	1,056	1,847
Tr16x4	●	●	528	2,111	2,639	1,583	1,056	1,847
Tr16x4	●	●	704	2,815	3,519	2,111	1,407	2,463
Tr18x4	●	●	679	2,362 ⁴³⁾	2,362 ⁴³⁾	2,362 ⁴³⁾	2,362 ⁴³⁾	2,362 ⁴³⁾
Tr18x4	●	●	679	2,714	3,393	2,036	1,357	2,375
Tr18x4	●	●	905	3,619	4,524	2,714	1,810	3,167

⁴³⁾ Reduced axial load due to nut geometry

Dimensions [mm]

d1 ¹⁵⁶⁾	d2 ¹⁵⁶⁾	b1 ¹⁵⁶⁾	Weight [g]					Part No.
			igidur®					
			J	W300	J350	R	A180	
8	14	18	2.8	2.9	2.7	2.6	2.7	<input type="checkbox"/> S <input type="checkbox"/> M-1418TR8X1.5
8	18	12	3.7	3.8	3.5	3.4	3.6	<input type="checkbox"/> S <input type="checkbox"/> M-1812TR8X1.5
10	22	15	6.7	7.0	6.5	6.3	6.6	<input type="checkbox"/> S <input type="checkbox"/> M-2215TR10X2
10	22	20	9.0	9.3	8.7	8.4	8.8	<input type="checkbox"/> S <input type="checkbox"/> M-2220TR10X2
10	22	15	6.7	7.0	6.5	6.3	6.6	<input type="checkbox"/> S <input type="checkbox"/> M-2215TR10X3
10	22	20	9.0	9.3	8.7	8.4	8.8	<input type="checkbox"/> S <input type="checkbox"/> M-2220TR10X3
12	26	18	11.2	11.6	10.8	10.5	11.0	<input type="checkbox"/> S <input type="checkbox"/> M-2618TR12X3
12	26	24	14.9	15.4	14.4	13.9	14.6	<input type="checkbox"/> S <input type="checkbox"/> M-2624TR12X3
14	30	28	23.1	23.8	22.3	21.5	22.6	<input type="checkbox"/> S <input type="checkbox"/> M-3028TR14X3
14	30	21	17.3	17.9	16.7	16.1	17.0	<input type="checkbox"/> S <input type="checkbox"/> M-3021TR14X4
14	30	28	23.1	23.8	22.3	21.5	22.6	<input type="checkbox"/> S <input type="checkbox"/> M-3028TR14X4
16	36	24	29.2	30.1	28.2	27.2	28.6	<input type="checkbox"/> S <input type="checkbox"/> M-3624TR16X2
16	36	32	38.9	40.2	37.6	36.3	38.2	<input type="checkbox"/> S <input type="checkbox"/> M-3632TR16X2
16	30	24	18.1	18.7	17.5	16.9	17.7	<input type="checkbox"/> S <input type="checkbox"/> M-3024TR16X4
16	36	24	29.2	30.1	28.2	27.2	28.6	<input type="checkbox"/> S <input type="checkbox"/> M-3624TR16X4
16	36	32	38.9	40.2	37.6	36.3	38.2	<input type="checkbox"/> S <input type="checkbox"/> M-3632TR16X4
18	30	27	18.2	18.8	17.6	17.0	17.8	<input type="checkbox"/> S <input type="checkbox"/> M-3027TR18X4
18	40	27	40.3	41.6	39.0	37.6	39.5	<input type="checkbox"/> S <input type="checkbox"/> M-4027TR18X4
18	40	36	53.8	55.5	52.0	50.1	52.7	<input type="checkbox"/> S <input type="checkbox"/> M-4036TR18X4

¹⁵⁶⁾ Tolerances according to DIN ISO 2768-1, tolerance class m (medium)

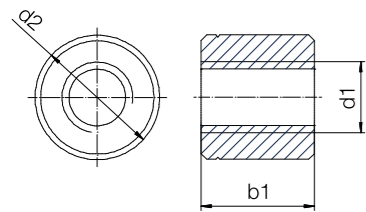

Order key

Type d2 b1 Thread

S R M-30 25 TR 20X4

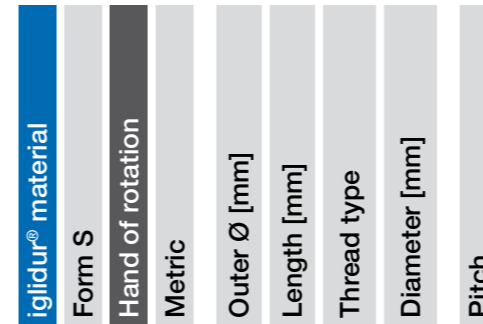

Options:
Hand of rotation
R: Right-hand thread
L: Left-hand thread

- J** High efficiency at all speeds
- W(300)** Extremely strong and wear-resistant
- J350** For temperatures up to +150°C
- R** The cost-effective option for high volume
- A180** FDA-compliant for the food and pharmaceutical industries

Technical data

Thread	Hand of rotation		Effective supporting surface [mm²]	Max. stat. axial F [N]				
	right	left		iglidur®				
				J	W300	J350	R	A180
Tr20x4	●	●	707	2,060 ⁴³⁾	3,534	2,121	1,414	2,474
Tr20x4	●	●	848	3,393	4,241	2,545	1,696	2,969
Tr20x4	●	●	1,131	4,524	5,655	3,393	2,262	3,958
Tr24x5	●	●	1,216	4,863	6,079	3,647	2,432	4,255
Tr24x5	●	●	1,621	6,484	8,105	4,863	3,242	5,674
Tr26x5	●	●	1,440	5,759	7,198	4,319	2,879	5,039
Tr26x5	●	●	1,920	7,678	9,598	5,759	3,839	6,718
Tr28x5	●	●	1,682	6,729	8,412	5,047	3,365	5,888
Tr28x5	●	●	2,243	8,972	11,215	6,729	4,486	7,851
Tr30x6	●	●	1,909	7,634	9,543	5,726	3,817	6,680
Tr30x6	●	●	2,545	10,179	12,723	7,634	5,089	8,906
Tr32x6	●	●	3,134	12,535	15,669	9,401	6,267	10,968
Tr36x6	●	●	3,732	14,929	18,661	-	-	13,063
Tr40x7	●	●	4,587	18,347	22,934	-	-	16,054
Tr50x8	●	●	7,226	28,903	-	-	-	-

⁴³⁾ Reduced axial load due to nut geometry

Dimensions [mm]

d1 ¹⁵⁶⁾	d2 ¹⁵⁶⁾	b1 ¹⁵⁶⁾	Weight [g]					Part No.
			iglidur®					
			J	W300	J350	R	A180	
20	30	25	14.6	15.1	14.1	13.6	14.3	<input type="checkbox"/> S <input type="checkbox"/> M-3025TR20X4
20	45	30	57.0	58.9	55.1	53.2	55.9	<input type="checkbox"/> S <input type="checkbox"/> M-4530TR20X4
20	45	40	76.1	78.5	73.5	71.0	74.5	<input type="checkbox"/> S <input type="checkbox"/> M-4540TR20X4
24	50	36	81.1	83.6	78.3	75.6	79.4	<input type="checkbox"/> S <input type="checkbox"/> M-5036TR24X5
24	50	48	108.1	111.5	104.4	100.8	105.9	<input type="checkbox"/> S <input type="checkbox"/> M-5048TR24X5
26	50	39	83.2	85.9	80.5	77.7	81.6	<input type="checkbox"/> S <input type="checkbox"/> M-5039TR26X5
26	50	52	111.0	114.5	107.3	103.5	108.8	<input type="checkbox"/> S <input type="checkbox"/> M-5052TR26X5
28	60	42	138.4	142.8	133.8	129.1	135.6	<input type="checkbox"/> S <input type="checkbox"/> M-6042TR28X5
28	60	56	184.5	190.4	178.3	172.2	180.8	<input type="checkbox"/> S <input type="checkbox"/> M-6056TR28X5
30	60	45	142.2	146.7	137.4	132.6	139.3	<input type="checkbox"/> S <input type="checkbox"/> M-6045TR30X6
30	60	60	189.6	195.6	183.2	176.9	185.8	<input type="checkbox"/> S <input type="checkbox"/> M-6060TR30X6
32	60	60	180.9	186.7	174.8	168.7	177.2	<input type="checkbox"/> S <input type="checkbox"/> M-6060TR32X6
36	75	72	364.8	376.4	-	-	357.4	<input type="checkbox"/> S <input type="checkbox"/> M-7572TR36X6
40	76	80	391.0	403.4	-	-	383.1	<input type="checkbox"/> S <input type="checkbox"/> M-7680TR40X7
50	90	100	655.3	-	-	-	-	<input type="checkbox"/> S <input type="checkbox"/> M-90100TR50X8

¹⁵⁶⁾ Tolerances according to DIN ISO 2768-1, tolerance class m (medium)

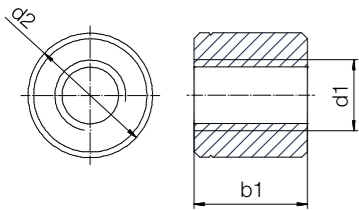

Order key

Type d2 b1 Thread

S R M-28 35 TR 12X6P3

iglidur® material	Form S
	Hand of rotation
	Metric
	Outer Ø [mm]
	Length [mm]
	Thread type
	Diameter [mm]
	Pitch

Options:
Hand of rotation
R: Right-hand thread
L: Left-hand thread

J	High efficiency at all speeds
W(300)	Extremely strong and wear-resistant
J350	For temperatures up to +150°C
R	The cost-effective option for high volume
A180	FDA-compliant for the food and pharmaceutical industries
E7	For high speeds

Technical data

Thread	Hand of rotation		Effective supporting surface [mm²]	Max. stat. axial F [N] iglidur®					
	right	left		J	W300	J350	R	A180	E7
Tr06x2P1	●	–	112	200 ⁴³⁾	200 ⁴³⁾	200 ⁴³⁾	200 ⁴³⁾	200 ⁴³⁾	56
Tr10x4P2	●	●	396	1,346	1,682	1,009	673	1,178	–
Tr12x6P3	●	●	396	1,346	1,682	1,009	673	1,178	–
Tr16x8P4	●	●	528	1,794	2,243	1,346	897	1,570	–
Tr16x8P4	●	●	704	2,393	2,991	1,794	1,196	2,094	–
Tr18x8P4	●	–	804	2,734	3,418	2,051	1,367	2,393	–
Tr20x8P4	●	–	1,131	3,845	4,807	2,884	1,923	3,365	–

⁴³⁾ Reduced axial load due to nut geometry

Dimensions [mm]

d1 ¹⁵⁶⁾	d2 ¹⁵⁶⁾	b1 ¹⁵⁶⁾	Weight [g] iglidur®						Part No.
			J	W300	J350	R	A180	E7	
6	14	13	2.4	2.5	2.4	2.3	2.4	2.4	<input type="checkbox"/> SRM-1413TR06X2P1
12	26	24	14.9	12.4	14.4	13.9	14.6	–	<input type="checkbox"/> S□M-2624TR10X4P2
12	30	24	21.2	17.7	20.5	19.8	20.8	–	<input type="checkbox"/> S□M-3024TR12X6P3
16	30	24	18.1	15.1	17.5	16.9	17.7	–	<input type="checkbox"/> S□M-3024TR16X8P4
16	36	32	38.9	32.4	37.6	36.3	38.2	–	<input type="checkbox"/> S□M-3632TR16X8P4
18	40	36	53.8	44.7	52.0	50.1	52.7	–	<input type="checkbox"/> SRM-4036TR18X8P4
20	45	40	76.1	63.3	73.5	71.0	74.5	–	<input type="checkbox"/> SRM-4540TR20X8P4

¹⁵⁶⁾ Tolerances according to DIN ISO 2768-1, tolerance class m (medium)

i Definition: Multi start trapezoidal lead screw
Example 8P4 pitch

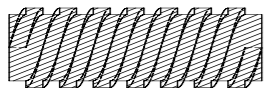

P4 pitch: Distance to the next thread pitch 4mm
Pitch 8: Pitch 8mm

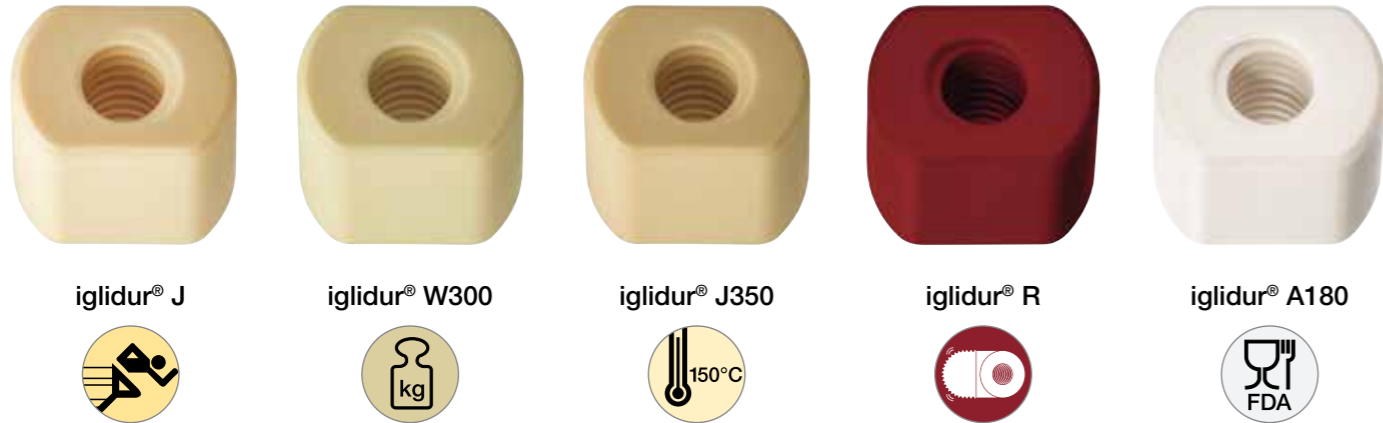

iglidur® J

iglidur® W300

iglidur® J350

iglidur® R

iglidur® A180

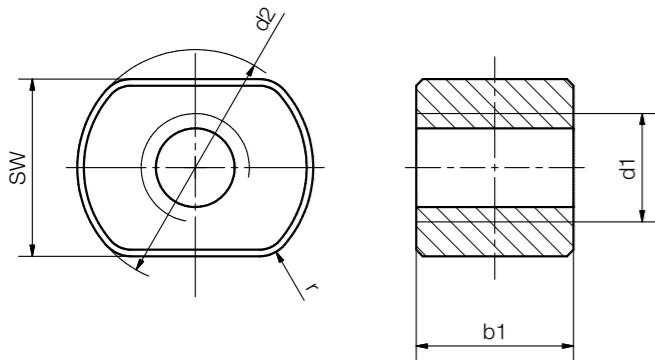
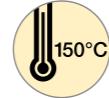

Technical data

Thread	Hand of rotation		Effective support surface [mm²]	Max. stat. axial F [N]				
	right	left		iglidur®				
				J	W300	J350	R	A180
Tr10x2	●	●	283	1,131	1,414	848	565	990
Tr12x3	●	●	396	1,583	1,979	1,188	792	1,385
Tr16x4	●	●	528	2,111	2,639	1,583	1,056	1,847
Tr20x4	●	●	1,131	4,524	5,655	3,393	2,262	3,958
Tr24x5	●	●	1,621	6,484	8,105	4,863	3,242	5,674
Tr30x6	●	●	2,545	10,179	12,723	7,634	5,089	8,906

Order key

Type SW d2 b1 Thread

□ S R M-17 22 20 TR 10X2

iglidur® material	Form S	Hand of rotation	Metric	Width across flats	Outer Ø [mm]	Length [mm]	Trapezoidal thread	Diameter [mm]	Pitch
-------------------	--------	------------------	--------	--------------------	--------------	-------------	--------------------	---------------	-------

Options:
Hand of rotation
R: Right-hand thread
L: Left-hand thread

- J** High efficiency at all speeds
- W(300)** Extremely strong and wear-resistant
- J350** For temperatures up to +150°C
- R** The cost-effective option for high volume
- A180** FDA-compliant for the food and pharmaceutical industries

Dimensions [mm]

d1 ¹⁵⁶⁾	d2 ¹⁵⁶⁾	b1 ¹⁵⁶⁾	SW	Weight [g]					Part No.
				iglidur®					
				J	W300	J350	R	A180	
10	22	20	17	4.7	3.9	4.5	4.4	4.6	□S□M-172220TR10X2
12	26	24	19	10.9	9.1	10.5	10.2	10.7	□S□M-192624TR12X3
16	36	24	27	22.0	18.3	21.3	20.5	21.6	□S□M-273624TR16X4
20	45	40	30	57.3	47.7	55.4	53.5	56.2	□S□M-304540TR20X4
24	50	48	36	75.7	63.0	73.2	70.6	74.2	□S□M-365048TR24X5
30	60	60	45	126.4	105.2	123.8	122.1	117.9	□S□M-456060TR30X6

¹⁵⁶⁾ Tolerances according to DIN ISO 2768-1, tolerance class m (medium)

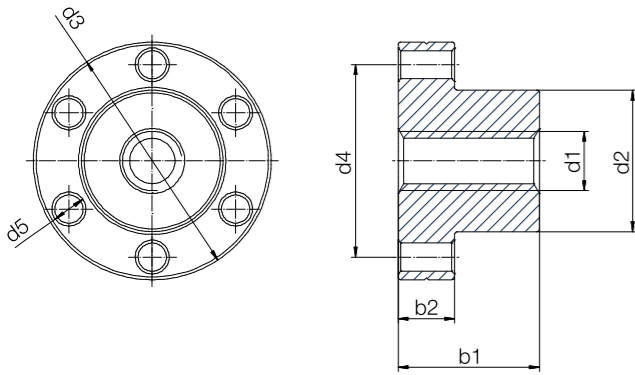

Technical data

Thread	Hand of rotation		Effective supporting surface [mm²]	Max. stat. axial F [N] iglidur®					
	right	left		J	W300	J350	R	A180	J200
Tr8x1.5	●	●	228	911	1,139	683	456	797	-
Tr10x2	●	●	353	1,414	1,767	1,060	707	1,237	-
Tr10x3	●	●	334	1,335	1,669	1,001	668	1,168	-
Tr12x3	●	●	577	2,309	2,886	1,732	1,155	2,020	-
Tr14x3	●	●	687	2,749	3,436	2,062	1,374	2,405	-
Tr14x4	●	●	660	2,639	3,299	1,979	1,319	2,309	-
Tr16x2	●	●	825	3,299	4,123	2,474	1,649	2,886	1,650
Tr16x4	●	●	770	3,079	3,848	2,309	1,539	2,694	1,540
Tr18x4	●	●	880	3,519	4,398	2,639	1,759	3,079	1,760
Tr20x4	●	●	1,244	4,976	6,220	3,732	2,488	4,354	2,488
Tr24x5	●	●	1,486	5,944	7,430	4,458	2,972	5,201	2,972
Tr26x5	●	●	1,698	6,320 ⁴³⁾	6,320 ⁴³⁾	6,320 ⁴³⁾	6,320 ⁴³⁾	6,320 ⁴³⁾	-
Tr28x5	●	●	1,843	4,560 ⁴³⁾	4,560 ⁴³⁾	4,560 ⁴³⁾	4,560 ⁴³⁾	4,560 ⁴³⁾	-
Tr30x6	●	●	1,951	3,576 ⁴³⁾	3,576 ⁴³⁾	3,576 ⁴³⁾	3,576 ⁴³⁾	3,576 ⁴³⁾	-
Tr30x6	●	●	1,951	7,804	9,755	-	-	6,828	-
Tr32x6	●	●	2,095	8,382	10,477	-	-	-	-
Tr36x6	●	●	3,629	14,514	-	-	-	-	-
Tr40x7	●	●	4,013	16,054	-	-	-	-	-

⁴³⁾ Reduced load due to nut geometry

Order key

Type d2 b1 Thread

F R M-22 20 TR 10X2

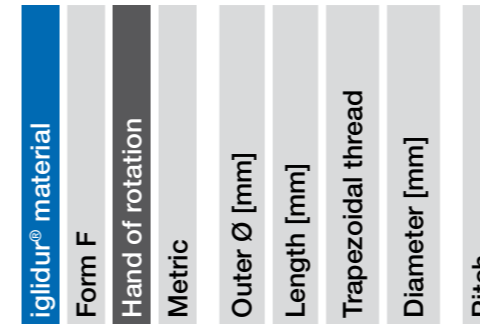

Options:
Hand of rotation
R: Right-hand thread
L: Left-hand thread

J	High efficiency at all speeds
W(300)	Extremely strong and wear-resistant
J350	For temperatures up to +150°C
R	The cost-effective option for high volume
A180	FDA-compliant for the food and pharmaceutical industries
J200	The specialist on hard anodised aluminium

Dimensions [mm]

d1 ¹⁵⁶⁾	d2 ¹⁵⁶⁾	d3	d4	d5	b1 ¹⁵⁶⁾	b2	Weight [g] iglidur®						Part No.
							J	W300	J350	R	A180	J200	
8	20	36	28	4	20	8	16.3	13.5	15.7	15.2	15.9	-	□F□M-2020TR8X1.5
10	25	42	34	5	25	10	28.7	23.9	27.7	26.8	28.1	-	□F□M-2525TR10X2
10	25	42	34	5	25	10	28.7	23.9	27.7	26.8	28.1	-	□F□M-2525TR10X3
12	28	48	38	6	35	12	47.6	39.6	46.0	44.4	46.6	-	□F□M-2835TR12X3
14	28	48	38	6	35	12	45.4	37.8	43.9	42.4	44.5	-	□F□M-2835TR14X3
14	28	48	38	6	35	12	45.4	37.8	43.9	42.4	44.5	-	□F□M-2835TR14X4
16	28	48	38	6	35	12	43.0	35.8	41.5	40.1	42.1	50	□F□M-2835TR16X2
16	28	48	38	6	35	12	43.0	35.8	41.5	40.1	42.1	50	□F□M-2835TR16X4
18	28	48	38	6	35	12	40.2	33.4	38.8	37.5	39.4	48	□F□M-2835TR18X4
20	32	55	45	7	44	12	60.2	50.1	58.2	56.2	59.0	73	□F□M-3244TR20X4
24	32	55	45	7	44	12	51.2	42.6	49.5	47.7	50.1	66	□F□M-3244TR24X5
26	38	62	50	7	46	14	80.7	67.1	78.0	75.2	79.0	-	□F□M-3846TR26X5
28	38	62	50	7	46	14	74.8	62.3	72.3	69.8	73.3	-	□F□M-3846TR28X5
30	38	62	50	7	46	14	68.6	57.1	66.3	64.0	67.2	-	□F□M-3846TR30X6
30	45	70	58	7	46	16	114.4	95.2	-	-	112.1	-	□F□M-4546TR30X6
32	45	70	58	7	46	16	72.6	60.4	-	-	-	-	□F□M-4546TR32X6
36	67	95	81	7	70	25	394.3	-	-	-	-	-	□F□M-6770TR36X6
40	67	95	81	7	70	25	369.4	-	-	-	-	-	□F□M-6770TR40X7

¹⁵⁶⁾ Tolerances according to DIN ISO 2768-1, tolerance class m (medium)

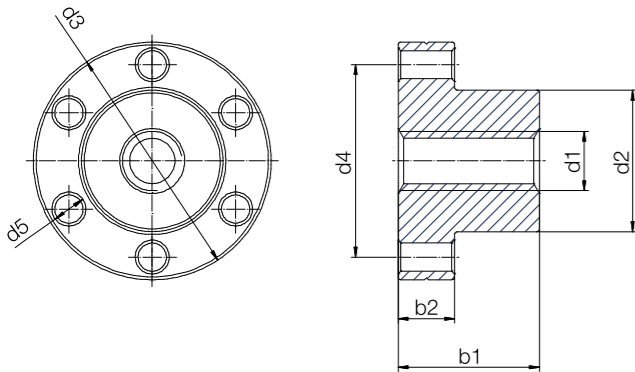

Technical data

Thread	Hand of rotation		Effective supporting surface [mm²]	Max. stat. axial F [N] iglidur®					
	right	left		J	W300	J350	R	A180	J200
Tr06x2P1	●	–	130	441	551	1,124	936	386	–
Tr10x4P2	●	–	353	1,202	1,502	1,051	3,064	2,552	–
Tr12x6P3	●	●	577	1,963	2,453	5,005	4,171	1,717	–
Tr16x8P4	●	●	770	2,617	3,271	6,673	5,561	2,290	1,540
Tr18x8P4	●	–	880	2,991	3,738	7,627	6,355	2,617	1,760
Tr20x8P4	●	–	1,244	4,230	5,287	10,786	8,988	3,701	2,488

i Definition: Multi start trapezoidal lead screw
Example 8P4 pitch

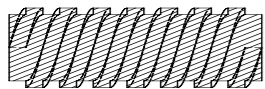

P4 pitch: Distance to the next thread pitch 4mm
Pitch 8: Pitch 8mm

Order key

Type d2 b1 Thread

F R M-28 35 TR 12X6P3

igidur® material	Form F	Hand of rotation	Metric	Outer Ø [mm]	Length [mm]	Thread type	Diameter [mm]	Pitch
------------------	--------	------------------	--------	--------------	-------------	-------------	---------------	-------

Options:
Hand of rotation
R: Right-hand thread
L: Left-hand thread

- J** High efficiency at all speeds
- W(300)** Extremely strong and wear-resistant
- J350** For temperatures up to +150°C
- R** The cost-effective option for high volume
- A180** FDA-compliant for the food and pharmaceutical industries
- J200** The specialist on hard anodised aluminium

Dimensions [mm]

d1 ¹⁵⁶⁾	d2 ¹⁵⁶⁾	d3	d4	d5	b1 ¹⁵⁶⁾	b2	Weight [g] iglidur®						Part No.	
							J	W300	J350	R	A180	J200		
6	13	25	19	3.2	15	5	5.0	4.2	4.8	4.7	4.9	–	–	□FRM-1315TR06X2P1
10	25	42	34	5	25	10	25.6	21.3	25.1	24.8	23.9	–	–	□FRM-2525TR10X4P2
12	28	48	38	6	35	12	47.6	39.6	46.0	44.4	46.6	–	–	□FRM-2835TR12X6P3
16	28	48	38	6	35	12	43.0	35.8	41.5	40.1	42.1	50	–	□FRM-2835TR16X8P4
18	28	48	38	6	35	12	40.2	33.4	38.8	37.5	39.4	48	–	□FRM-2835TR18X8P4
20	32	55	45	7	44	12	60.2	50.1	58.2	56.2	59.0	73	–	□FRM-3244TR20X8P4

¹⁵⁶⁾ Tolerances according to DIN ISO 2768-1, tolerance class m (medium)



igidur® J



igidur® W300



igidur® J350

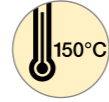

igidur® R



igidur® A180

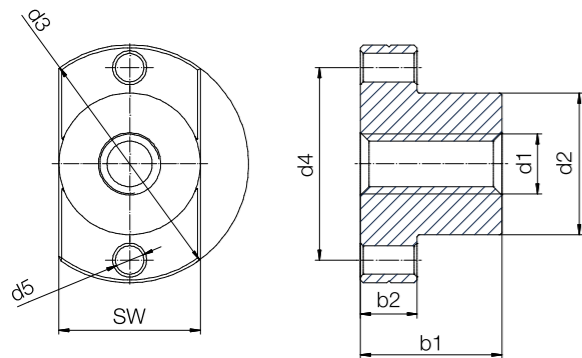

Technical data

Thread	Hand of rotation		Effective support surface [mm²]	Max. stat. axial F [N]				
	right	left		igidur®				
single start				J	W300	J350	R	A180
Tr8x1.5	●	●	228	911	1,139	683	456	797
Tr10x2	●	●	353	1,414	1,767	1,060	707	1,237
Tr12x3	●	●	577	2,309	2,886	1,732	1,155	2,020
Tr14x4	●	●	660	2,639	3,299	1,979	1,319	2,309
Tr16x4	●	●	770	3,079	3,848	2,309	1,539	2,694
Tr18x4	●	●	880	3,519	4,398	2,639	1,759	3,079
Multi start								
Tr06x2P1	●	–	118	175 ⁴³⁾	175 ⁴³⁾	175 ⁴³⁾	175 ⁴³⁾	175 ⁴³⁾
Metric								
M5	●	–	56	75 ⁴³⁾	75 ⁴³⁾	75 ⁴³⁾	75 ⁴³⁾	75 ⁴³⁾
M8	●	–	278	911	1,139	683	456	797
M10	●	–	437	1,414	1,767	1,040	1,155	1,237

⁴³⁾ Reduced load due to nut geometry

Order key

Type	SW	d2	b1	Thread
------	----	----	----	--------

□ F R M-131313TR6X2P1

igidur® material	Form F	Hand of rotation	Metric	Width across flats	Outer Ø [mm]	Length [mm]	Trapezoidal thread	Diameter [mm]	Pitch
------------------	--------	------------------	--------	--------------------	--------------	-------------	--------------------	---------------	-------

Options:
Hand of rotation
R: Right-hand thread
L: Left-hand thread

- J** High efficiency at all speeds
- W(300)** Extremely strong and wear-resistant
- J350** For temperatures up to +150°C
- R** The cost-effective option for high volume
- A180** FDA-compliant for the food and pharmaceutical industries

Dimensions [mm]

d1 ¹⁵⁶⁾	d2 ¹⁵⁶⁾	d3	d4	d5	b1 ¹⁵⁶⁾	b2	SW	Weight [g]					Part No.
								igidur®					
								J	W300	J350	R	A180	
8	20	36	28	4	20	8	20	12.7	10.6	–	–	12.4	□F□M-202020TR8X1.5
10	25	42	34	5	25	10	25	23.7	19.7	12.28	22.10	23.2	□F□M-252525TR10X2
12	28	48	38	6	35	12	28	39.2	32.7	37.92	36.60	38.4	□F□M-282835TR12X3
14	28	48	38	6	35	12	28	37.1	30.9	35.86	34.61	36.4	□F□M-282835TR14X4
16	28	48	38	6	35	12	28	34.6	28.8	33.48	32.32	33.9	□F□M-282835TR16X4
18	28	48	38	6	35	12	28	31.9	26.5	30.79	29.72	31.2	□F□M-282835TR18X4
6	13	25	19	3.2	15	5	13	3.8	3.1	3.5	–	3.7	□FRM-131315TR06X2P1
5	9	18	15.2	3.2	13	3	9	1.3	1.1	1.2	–	1.3	□FRM-090913M5
8	20	36	28	4	20	8	20	12.7	10.57	12.28	11.85	12.45	□FRM-202020M8
10	25	42	34	5	25	10	25	23.7	19.70	22.90	22.10	23.20	□FRM-252525M10

¹⁵⁶⁾ Tolerances according to DIN ISO 2768-1, tolerance class m (medium)

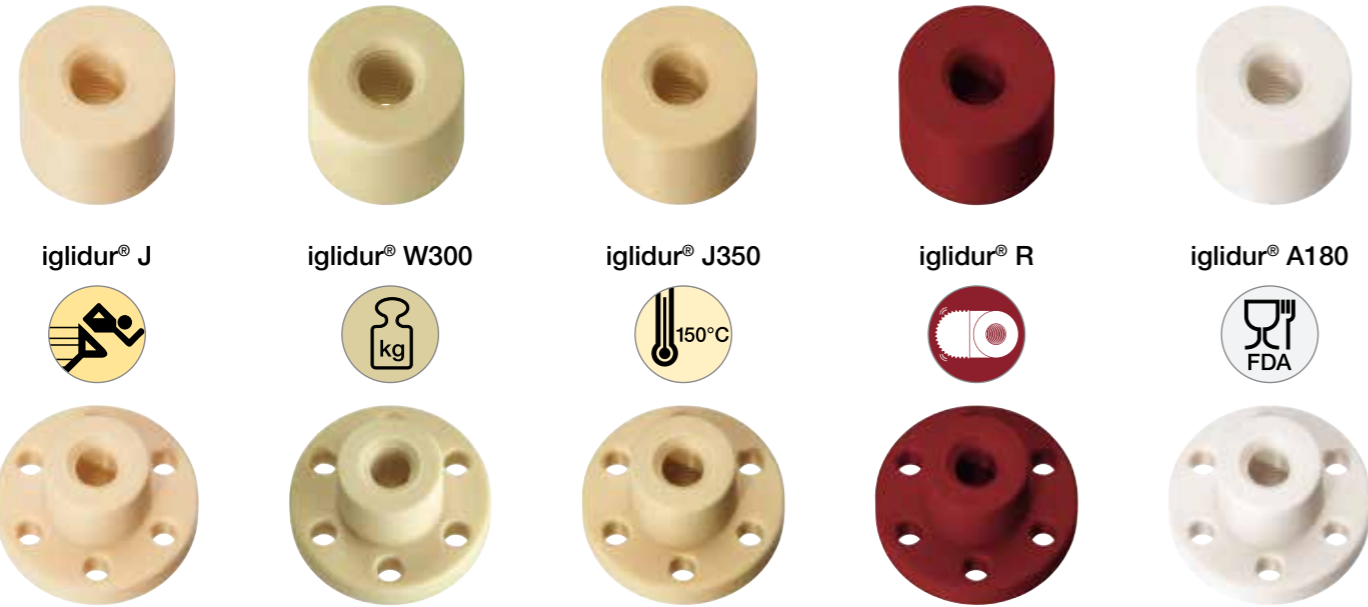

i Also available as flanged nut and spanner flats ▶ Page 1312

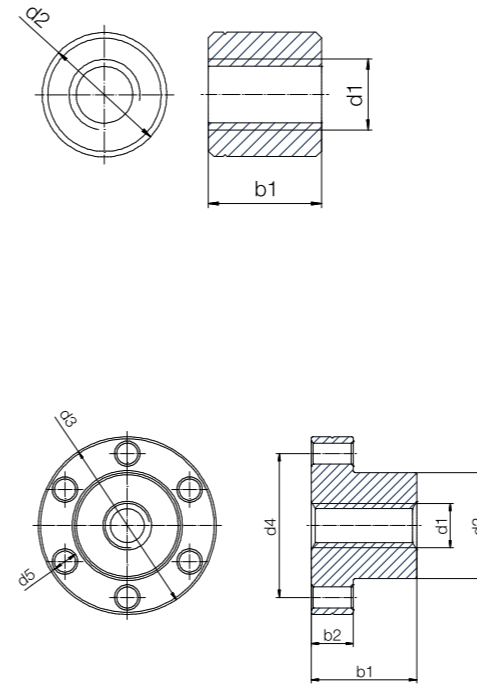

Order key

Type	d2	b1	Thread
<input type="checkbox"/> S	R	M-14	13M3

Options:
Form S: Cylindrical
Form F: With flange

Material	Form	Hand of rotation	Metric	Outer Ø [mm]	Length [mm]	Diameter
igidur®	S					
J		High efficiency at all speeds				
W(300)		Extremely strong and wear-resistant				
J350		For temperatures up to +150°C				
R		The cost-effective option for high volume				
A180		FDA-compliant for the food and pharmaceutical industries				

Technical data

Thread	Effective supporting surface [mm²]	Max. stat. axial F [N]				
		igidur®				
		J	W300	J350	R	A180
Cylindrical (form S)						
M3	56	225	281	168	112	197
M4	75	298	373	224	149	261
M5	94	376	470	282	188	329
M6	112	449	562	337	225	393
M8	151	602	753	452	301	527
M10	189	756	944	567	378	661
With flange (form F)						
M3	56	225	281	168	112	197
M4	75	298	373	224	149	261
M5	94	376	470	282	188	329
M6	130	518	648	389	259	454
M8	228	911	1,139	683	456	797
M10	253	1,414	1,767	1,060	707	1,237

Dimensions [mm]

d1 ¹⁵⁶⁾	d2 ¹⁵⁶⁾	b1 ¹⁵⁶⁾	Weight [g]					Part No.				
			igidur®									
			J	W300	J350	R	A180					
3	14	13	2.8	2.4	2.7	2.7	2.8	<input type="checkbox"/> SRM-1413M3				
4	14	13	2.7	2.3	2.6	2.6	2.7	<input type="checkbox"/> SRM-1413M4				
5	14	13	2.6	2.2	2.5	2.4	2.5	<input type="checkbox"/> SRM-1413M5				
6	14	13	2.4	2.0	2.4	2.3	2.4	<input type="checkbox"/> SRM-1413M6				
8	20	18	7.08	5.89	6.69	6.60	6.94	<input type="checkbox"/> SRM-2018M8				
10	22	20	8.99	7.48	8.69	8.38	8.81	<input type="checkbox"/> SRM-2220M10				
d1	d2	d3	d4	d5	b1	b2						
3	9	18	15.2	3.2	13	3	1.9	1.6	1.9	1.8	1.9	<input type="checkbox"/> FRM-0913M3
4	9	18	15.2	3.2	13	3	1.8	1.5	1.8	1.7	1.8	<input type="checkbox"/> FRM-0913M4
5	9	18	15.2	3.2	13	3	1.7	1.4	1.6	1.6	1.7	<input type="checkbox"/> FRM-0913M5
6	13	25	19	3.2	15	5	4.7	3.9	4.5	4.4	4.6	<input type="checkbox"/> FRM-1315M6
8	20	36	28	4	20	8	16.25	13.53	15.93	15.71	15.17	<input type="checkbox"/> FRM-2020M8
10	25	42	34	5	25	10	28.69	23.88	28.11	27.73	26.76	<input type="checkbox"/> FRM-2525M10

¹⁵⁶⁾ Tolerances according to DIN ISO 2768-1, tolerance class m (medium)

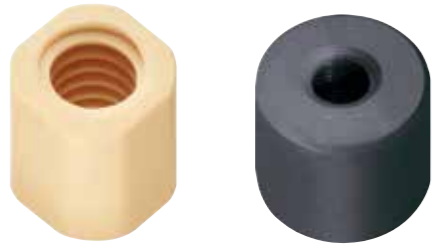
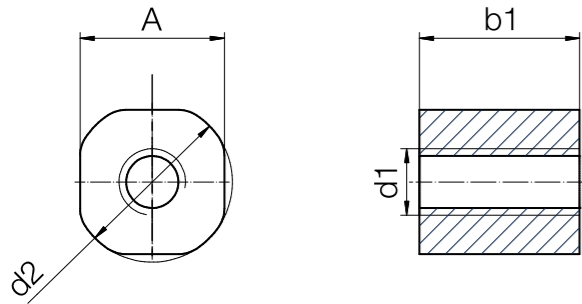

Image exemplary



Technical data

Thread	Hand of rotation		Effective supporting surface [mm²]	Max. static axial F [N]
	right	left		
Single start				
Tr8x1.5	●	●	228	500 ⁴³⁾
Tr8x1.5	●	–	228	114.0
Tr10x2	●	●	283	1,131
Tr10x2	●	–	238	119.0
Tr10x3	●	●	267	1,068
Tr10x3	●	–	267	134.0
Tr12x3	●	●	412	1,649
Tr12x3	●	–	412	206.0
Tr14x3	●	●	491	1,963
Tr14x3	●	–	491	245.5
Tr14x4	●	●	471	1,885
Tr14x4	●	–	471	235.5
Tr16x2	●	●	589	2,356
Tr16x4	●	–	550	2,199
Tr18x4	●	●	628	2,362
multi start				
Tr10x4P2	●	–	325	1,106
Tr12x6P3	●	–	396	1,346
Tr16x8P4	●	–	528	1,794
Tr18x8P4	●	–	804	2,734

⁴³⁾ Reduced load due to nut geometry

Order key

Type	d2	b1	Thread
J S □ M - C - 01 - TR 10X12			
iglidur® material	Form S	Hand of rotation	Metric
		Thread: cut	Type
		Thread type	Diameter [mm]
		Pitch	

Options:
Hand of rotation
R: Right-hand thread
L: Left-hand thread

J High efficiency at all speeds
E7 For high speeds

Dimensions [mm]

d1 ¹⁵⁶⁾	d2 ¹⁵⁶⁾	A	b1 ¹⁵⁶⁾	Weight [g]	Part No.
8	20	19	20	7.86	JS□M-C-01-TR8X1.5
8	20	18	20	5.00	E7SRM-C-01-TR8X1.5 New
10	20	19	20	7.02	JS□M-C-01-TR10X2
10	20	18	20	5.00	E7SRM-C-01-TR10X2 New
10	20	19	20	7.02	JS□M-C-01-TR10X3
10	20	18	20	5.00	E7SRM-C-01-TR10X3 New
12	24	22.6	25	12.64	JS□M-C-01-TR12X3
12	24	22.6	25	9.80	E7SRM-C-01-TR12X3 New
14	24	22.6	25	11.12	JS□M-C-01-TR14X3
14	24	22.6	25	9.80	E7SRM-C-01-TR14X3 New
14	24	22.6	25	11.12	JS□M-C-01-TR14X4
14	24	22.6	25	9.80	E7SRM-C-01-TR14X4 New
16	28	26.2	25	15.45	JS□M-C-01-TR16X2
16	28	26.2	25	15.45	JS□M-C-01-TR16X4
18	28	26.2	25	13.46	JS□M-C-01-TR18X4
10	20	19	20	7.02	JSRM-C-01-TR10X4P2
12	24	22.6	25	12.64	JSRM-C-01-TR12X6P3
16	28	26.2	25	15.45	JSRM-C-01-TR16X8P4
18	28	26.2	25	13.46	JSRM-C-01-TR18X8P4

¹⁵⁶⁾ Tolerances according to DIN ISO 2768-1, tolerance class m (medium)

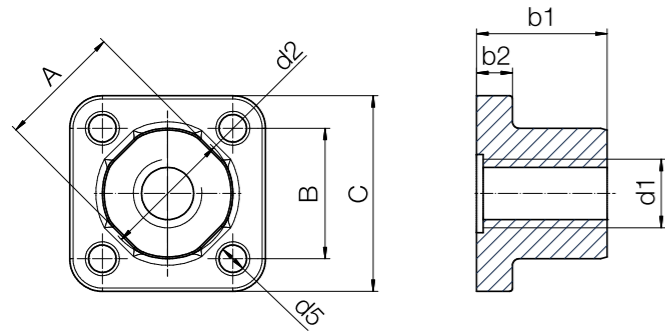
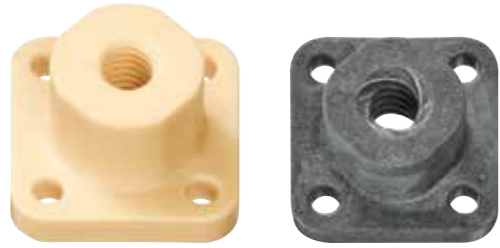

Technical data

Thread	Hand of rotation		Effective supporting surface [mm²]	Max. stat. axial F [N]	
	right	left		iglidur®	
				J	E7
Single start					
Tr8x1.5	●	●	228	911	114
Tr10x2	●	●	283	1,131	142
Tr10x3	●	●	267	1,068	134
Tr12x3	●	●	412	1,649	-
Tr14x3	●	●	491	1,963	-
Tr14x4	●	●	471	1,885	-
Tr16x2	●	●	589	2,356	-
Tr16x4	●	●	550	2,199	-
Tr18x4	●	●	628	2,513	-
multi start					
Tr10x4P2	●	-	353	1,202	134
Tr12x6P3	●	-	577	1,963	-
Tr16x8P4	●	-	770	2,617	-
Tr18x8P4	●	-	880	2,991	-

Order key

Type d2 b1 Thread

J F □ M - C - 01 - TR 10X12

Options:
Hand of rotation
R: Right-hand thread
L: Left-hand thread

iglidur® material

Form F

Hand of rotation

Metric

Thread: cut

Type

Thread type

Diameter [mm]

Pitch

J High efficiency at all speeds

E7 For high speeds

Dimensions [mm]

d1 ¹⁵⁶⁾	d2 ¹⁵⁶⁾	A	B	C	d5	b1 ¹⁵⁶⁾	b2	Weight [g]		Part No.
								iglidur®		
								J	E7	
8	20	19.0	20	30	4.2	20	5.5	7.4	1.9	□F□M-C-01-TR8X1.5
10	20	19.0	20	30	4.2	20	5.5	7.4	9.0	□F□M-C-01-TR10X2
10	20	19.0	20	30	4.2	20	5.5	7.4	9.0	□F□M-C-01-TR10X3
12	24	22.6	24	34	5	25	6	10.3	-	JF□M-C-01-TR12X3
14	24	22.6	24	34	5	25	6	10.3	-	JF□M-C-01-TR14X3
14	24	22.6	24	34	5	25	6	10.3	-	JF□M-C-01-TR14X4
16	28	25.5	27	38	6	25	6.5	14.0	-	JF□M-C-01-TR16X2
16	28	25.5	27	38	6	25	6.5	14.0	-	JF□M-C-01-TR16X4
18	28	25.5	27	38	6	25	6.5	14.0	-	JF□M-C-01-TR18X4
10	20	19.0	20	30	4.2	20	5.5	10.9	9.0	□FRM-C-01-TR10X4P2
12	24	22.6	24	34	5	25	6	19.9	-	JFRM-C-01-TR12X6P3
16	28	25.5	27	38	6	25	6.5	25.4	-	JFRM-C-01-TR16X8P4
18	28	25.5	27	38	6	25	6.5	23.9	-	JFRM-C-01-TR18X8P4

¹⁵⁶⁾ Tolerances according to DIN ISO 2768-1, tolerance class m (medium)

Cylindrical (form S)



With flange (form F)

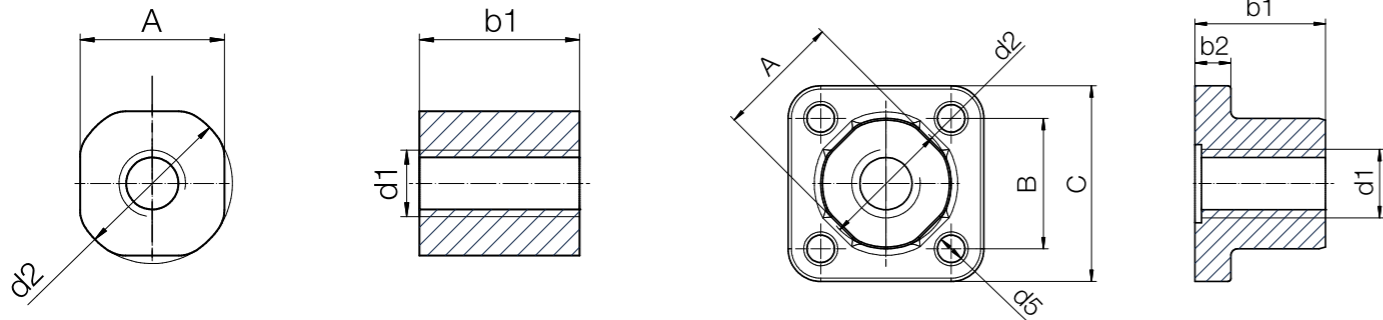

Technical data

Thread	Effective supporting surface [mm ²]	Max. static axial F [N]
Cylindrical (form S)		
M5	94	376
M6	112	449
M8	151	602
With flange (form F)		
M5	90	358
M6	104	415
M8	232	927

Order key

Type d2 b1 Thread

J S R M - C - 01 - M5

iglidur® material	Form S	Hand of rotation	Metric	Thread: cut	Type	Diameter
-------------------	--------	------------------	--------	-------------	------	----------

Options:
Form S: Cylindrical
Form F: With flange

Dimensions [mm]

d1 ¹⁵⁶⁾	d2 ¹⁵⁶⁾	A	b1 ¹⁵⁶⁾	Weight [g]	Part No.
5	12	11	12	1.67	JSRM-C-01-M5
6	12	11	12	1.52	JSRM-C-01-M6
8	20	19	20	7.86	JSRM-C-01-M8

d1	d2	A	B	C	d5	b1	b2	[g]	Part No.
5	12	11	12	18	3.2	12	4	3.05	JFRM-C-01-M5
6	12	11	12	18	3.2	12	4	2.94	JFRM-C-01-M6
8	20	19	20	30	4.2	20	5.5	13.08	JFRM-C-01-M8

¹⁵⁶⁾ Tolerances according to DIN ISO 2768-1, tolerance class m (medium)

Cylindrical (form S)



With flange (form F)

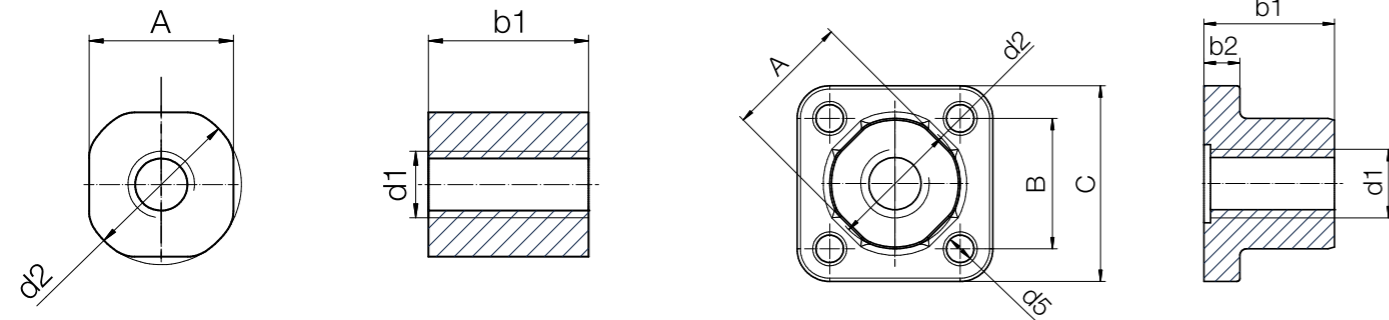

Technical data

Thread	Effective supporting surface [mm²]	Max. static axial F [N]
Cylindrical (form S)		
Tr8x1.5	228	500 ⁴³⁾
Tr10x2	283	1,131
Tr16x4	550	2,199
With flange (form F)		
Tr8x1.5	118	471
Tr10x2	228	911
Tr16x4	353	1,414

⁴³⁾ Reduced load due to nut geometry

Order key

Type d2 b1 Thread

J F R M-M-01-TR 10X12

iglidur® material	Form F	Hand of rotation	Metric	Thread: injectionmoulding	Type	Thread type	Diameter [mm]	Pitch
-------------------	--------	------------------	--------	---------------------------	------	-------------	---------------	-------

Options:
Form S: Cylindrical
Form F: With flange

Dimensions [mm]

d1 ¹⁵⁶⁾	d2 ¹⁵⁶⁾	A	b1 ¹⁵⁶⁾	Weight [g]	Part No.
8	20	19	20	7.86	JSRM-M-01-TR8X1.5
10	20	19	20	7.02	JSRM-M-01-TR10X2
16	28	26.16	25	15.45	JSRM-M-01-TR16X4

d1	d2	A	B	C	d5	b1	b2	[g]	Part No.
8	20	19	20	30	4.2	20	5.5	7.38	JFRM-M-01-TR8X1.5
10	20	19	20	30	4.2	20	5.5	7.38	JFRM-M-01-TR10X2
16	28	25.5	27	38	6	25	6.5	13.99	JFRM-M-01-TR16X4

¹⁵⁶⁾ Tolerances according to DIN ISO 2768-1, tolerance class m (medium)

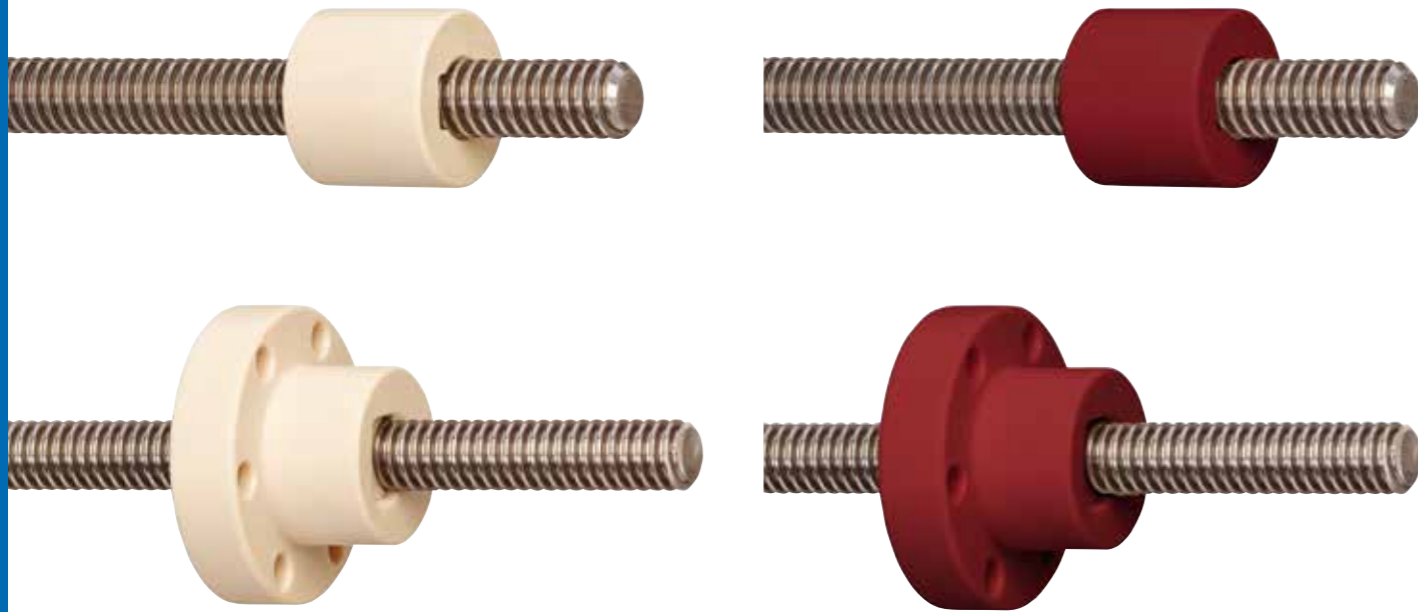

Backlash is the phenomenon created on the lead screw drive by the axial clearance. By adding a radial pre-load, vibrations are significantly reduced.

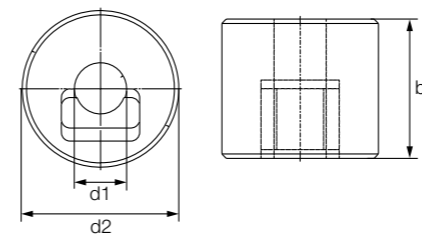

Cylindrical (form S)

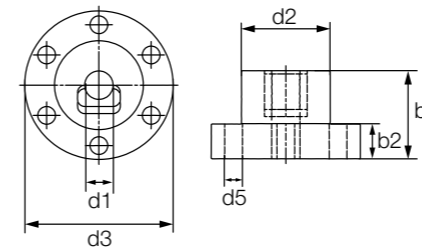

With flange (form F)

Order key

Type	d2	b1	Thread
S R M-AB-25 25 TR 10X2			
iglidur® material	Form S	Hand of rotation	Metric
Anti-backlash	Outer Ø [mm]	Length [mm]	Trapezoidal thread
Diameter [mm]	Pitch	Options: Form S: Cylindrical Form F: With flange	
J		High efficiency at all speeds	
R		The cost-effective option for high volume	

Technical data – cylindrical design

Thread	Hand of rotation		Effective supporting surface [mm ²]	Max. stat. axial F [N] iglidur®	
	right	left		J	R
Cylindrical – form S					
Tr8x1.5	●	–	228	683	342
Tr10x2	●	–	283	848	424
Tr12x3	●	–	396	1,188	594
Tr16x4	●	–	704	2,111	1,056
Tr18x4	●	–	905	2,714	1,357
Tr20x4	●	–	1,131	3,393	1,696
Tr24x5	●	–	1,621	4,863	2,432

Technical data – with flange

Thread	Hand of rotation		Effective supporting surface [mm ²]	Max. stat. axial F [N] iglidur®	
	right	left		J	R
With flange – form F					
Tr10x2	●	–	353	1,060	530
Tr10x3	●	–	334	1,001	501
Tr12x3	●	–	396	1,188	594
Tr14x4	●	–	471	1,414	707
Tr16x2	●	–	613	1,838	919
Tr16x4	●	–	704	2,111	1,056
Tr18x4	●	–	905	2,714	1,357
Tr20x4	●	–	1,131	3,393	1,696
Tr24x5	●	–	1,621	4,863	2,432

Dimensions [mm] – cylindrical design

d1 ¹⁵⁶⁾	d2 ¹⁵⁶⁾	b1 ¹⁵⁶⁾	Weight [g] iglidur®		Part No.
			J	R	
8	22	20	9.8	9.2	SRM-AB-2220-TR8X1.5
10	22	20	9.0	8.4	SRM-AB-2220-TR10X2
12	26	24	14.9	13.9	SRM-AB-2624-TR12X3
16	36	32	38.9	36.3	SRM-AB-3632-TR16X4
18	40	36	53.8	50.1	SRM-AB-4036-TR18X4
20	45	40	76.1	71.0	SRM-AB-4540-TR20X4
24	50	48	108.1	100.8	SRM-AB-5048-TR24X5

Dimensions [mm] – with flange

d1 ¹⁵⁶⁾	d2 ¹⁵⁶⁾	d3	d4	d5	b1 ¹⁵⁶⁾	b2	Weight [g] iglidur®		Part No.
							J	R	
10	25	42	34	5	25	10	28.7	26.8	FRM-AB-2525-TR10X2
10	25	42	34	5	25	10	28.7	26.8	FRM-AB-2525-TR10X3
12	28	48	35	5	35	12	30.3	28.3	FRM-AB-2835-TR12X3
14	28	48	38	6	35	12	45.4	42.4	FRM-AB-2835-TR14X4
16	28	48	38	6	35	12	43.0	40.1	FRM-AB-2835-TR16X2
16	28	48	38	6	35	12	43.0	40.1	FRM-AB-2835-TR16X4
18	28	48	38	6	35	12	40.2	37.5	FRM-AB-2835-TR18X4
20	32	55	45	7	44	12	60.2	56.2	FRM-AB-3244-TR20X4
24	32	55	45	7	44	12	51.2	47.7	FRM-AB-3244-TR24X5

¹⁵⁶⁾ Tolerances according to DIN ISO 2768-1, tolerance class m (medium)

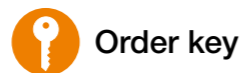

Type Thread

J F R M-LC-0001-TR 10X2

iglidur® material	Form F	Hand of rotation	Metric	Low Clearance	Type	Trapezoidal thread	Diameter [mm]	Pitch
-------------------	--------	------------------	--------	---------------	------	--------------------	---------------	-------

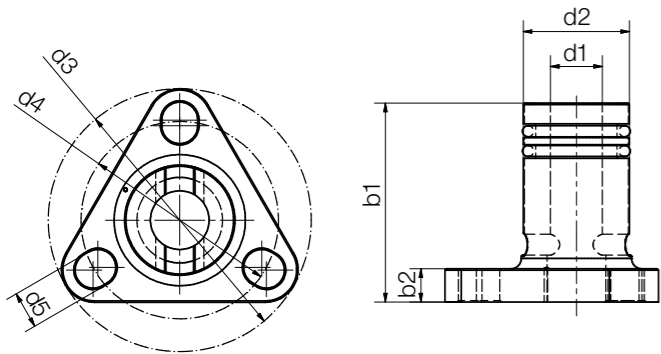

Technical data

Thread	Max. stat. axial F [N]	Max. idling torque (with O-ring) [Nm]	Weight [g]	Part No.
Single start				
Tr8x1.5	75	0.01–0.03	6.8	JFRM-LC-0001-TR8X1.5
Tr10x2	75	0.01–0.03	6.8	JFRM-LC-0001-TR10X2
Tr10x3	75	0.01–0.03	6.8	JFRM-LC-0001-TR10X3
Tr12x3	125	0.06	18.0	JFRM-LC-0001-TR12X3
Tr14x3	125	0.08	18.0	JFRM-LC-0001-TR14X3
Tr14x4	125	0.08	18.0	JFRM-LC-0001-TR14X4
Multi start				
Tr06x2P1	40	0.01–0.03	3.9	JFRM-LC-0001-TR06X2P1
Tr12x6P3	125	0.06	18.0	JFRM-LC-0001-TR12X6P3

Dimensions [mm]

Thread	d1 ¹⁵⁶⁾	d2 ¹⁵⁶⁾	d3	d4	d5	b1 ¹⁵⁶⁾	b2	Part No.
Single start								
Tr8x1.5	8	16.0	38.1	28.3	5.2	28.3	4.8	JFRM-LC-0001-TR8X1.5
Tr10x2	10	16.0	38.1	28.3	5.2	28.3	4.8	JFRM-LC-0001-TR10X2
Tr10x3	10	16.0	38.1	28.3	5.2	28.3	4.8	JFRM-LC-0001-TR10X3
Tr12x3	12	20	41.2	31.8	4.8	44.0	7.0	JFRM-LC-0001-TR12X3
Tr14x3	14	20	41.2	31.8	4.8	44.0	7.0	JFRM-LC-0001-TR14X3
Tr14x4	14	20	41.2	31.8	4.8	44.0	7.0	JFRM-LC-0001-TR14X4
Multi start								
Tr06x2P1	6	10.0	28.5	22.2	3.7	25.0	4.1	JFRM-LC-0001-TR06X2P1
Tr12x6P3	12	20	41.2	31.8	4.8	44.0	7.0	JFRM-LC-0001-TR12X6P3

¹⁵⁶⁾ Tolerances according to DIN ISO 2768-1, tolerance class m (medium)



drylin® lead screw technology – Special designs

Angular compensation with spherical balls

With "Fast Forward" quick release mechanism

Split lead screw nuts

Accessories for lead screw nuts and lead screws

Lubrication and maintenance-free





Order key

Part number	Dimension	Thread
-------------	-----------	--------

J T R M- 22 30 -TR 10X2

igidur® material	Split nut	Hand of rotation	Metric	d2	b1	Trapezoidal thread	Diameter [mm]	Pitch
------------------	-----------	------------------	--------	----	----	--------------------	---------------	-------

This part includes 2 nut halves and 1 piece nut each based on DIN 934 made from 304 stainless steel to prevent twisting

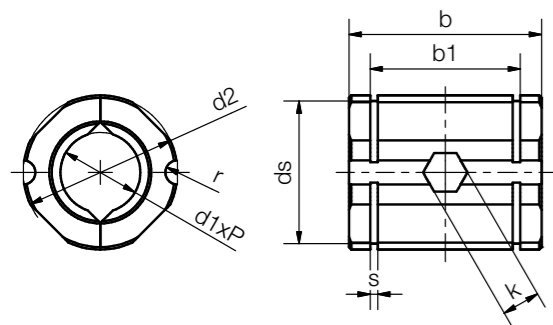

Technical data

Part No.	max. axial load		Mounting with nut
	static ⁵⁰⁾ [N]	static ⁵¹⁾ [N]	
JTRM-2230TR10X2	300	500	DIN 934 M4
JTRM-3240TR20X4	1,000	1,500	M5
JTRM-3240TR20X8P4	1,000	1,500	M5

Dimensions [mm]

Thread	b	b1 ¹⁵⁶⁾	d2	ds	k	r	s	Part No.
Tr10x2	30	22.6	22	20.5	7	1.5	1.3	JTRM-2230TR10X2
Tr20x4	40	31.2	32	29.6	8	2.5	1.6	JTRM-3240TR20X4
Tr20x8P4	40	31.2	32	29.6	8	2.5	1.6	JTRM-3240TR20X8P4

⁵⁰⁾ Mounting in the housing via radially inserted nut DIN 934

⁵¹⁾ Mounting in the housing via circlips DIN 471

¹⁵⁶⁾ Tolerances according to DIN ISO 2768-1, tolerance class m (medium)



Order key

Part number	Thread
-------------	--------

RG A S - J T R M-TR 10X2

Linear housing	Aluminium	Small	igidur® material	Split nut	Hand of rotation	Metric	Trapezoidal thread	Diameter [mm]	Pitch
----------------	-----------	-------	------------------	-----------	------------------	--------	--------------------	---------------	-------

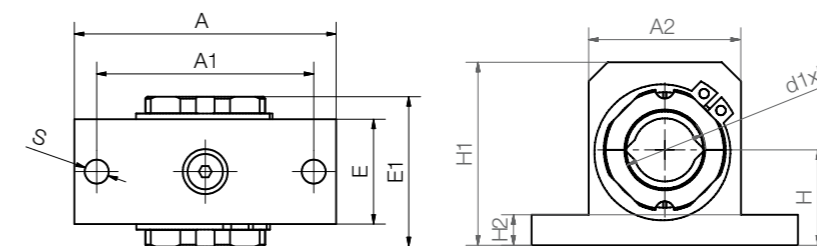

Technical data

Part No.	Nut	Locking ring
RGAS-JTRM-TR10X2	DIN 439 M4	DIN 471-A22
RGAS-JTRM-TR20X4	DIN 439 M5	DIN 471-A32
RGAS-JTRM-TR20X8P4	DIN 439 M5	DIN 471-A32

Dimensions [mm]

Thread	H	H1	H2	A	A1	A2	E	E1	S	Part No.
Tr10x2	18	35	6	52	42	30	20	32	5.3	RGAS-JTRM-TR10X2
Tr20x4	25	48	8	70	58	40	28	40	6.4	RGAS-JTRM-TR20X4
Tr20x8P4	25	48	8	70	58	40	28	40	6.4	RGAS-JTRM-TR20X8P4

Square lead screw nuts



DST-SHT-1210

SHT-1210-TR

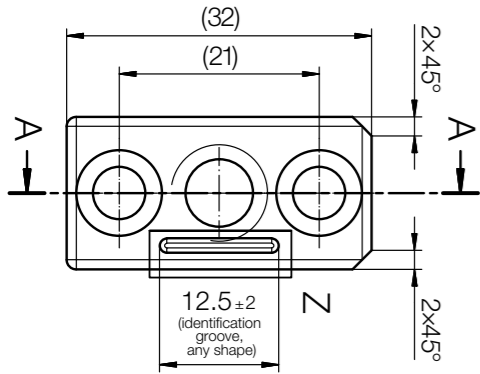

Order key

Order example

DST-SHT-1210-DS10x12- J - □



Options:
Hand of rotation
RH: Right-Hand
LH: Left-hand

Dimensions

Part No.	Hand of rotation		Thread d1xP	From SHT linear module	
	right	left			
DST-SHT-1210-DS10x12-J-□	●	●	Ds10x12	SHT-12	► Page 1372
DST-SHT-1210-DS10x25-J-□	●	●	Ds10x25	SHT-12	► Page 1372
DST-SHT-1210-DS10x50-J-□	●	●	Ds10x50	SHT-12	► Page 1372
SHT-1210-TR10X2-J-□	●	●	Tr10x2	SHT-12	► Page 1372
SHT-1210-TR10X3-J-□	●	●	Tr10x3	SHT-12	► Page 1372

Part number suffix LH for left-hand thread, RH for right-hand thread

Lead screw nuts with flange



DST-SHT-2018

SHT-2018-TR

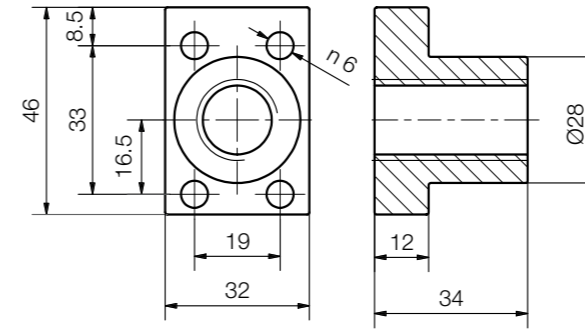

Order key

Order example

DST-SHT-2018-DS18x24- J - □

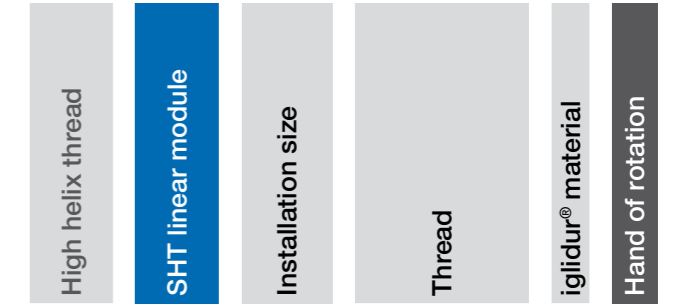

Options:
Hand of rotation
RH: Right-Hand
LH: Left-hand

Please note: not symmetrical

Dimensions

Part No.	Hand of rotation		Thread d1xP	From SHT linear module	
	right	left			
DST-SHT-2018-DS18x24-J-□	●	●	Ds18x24	SHT-20	► Page 1372
DST-SHT-2018-DS18x40-J-□	●	●	Ds18x40	SHT-20	► Page 1372
DST-SHT-2018-DS18x80-J-□	●	●	Ds18x80	SHT-20	► Page 1372
DST-SHT-2018-DS18x100-J-□	●	●	Ds18x100	SHT-20	► Page 1372
SHT-2018-TRM-18X4-□	●	●	Tr18x4	SHT-20	► Page 1372
SHT-2018-TRM-18X8-□	●	●	Tr18x8p4	SHT-20	► Page 1372

Part number suffix LH for left-hand thread, RH for right-hand thread

Lead screw nuts



DST-SLW-063001 SWZ-063009

Order key

Order example

DST-SLW-063001-DS8x10-□



Options:
Hand of rotation
RH: Right-Hand
LH: Left-hand

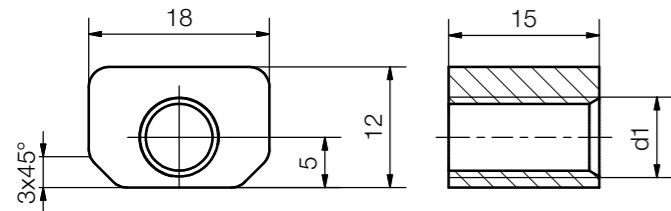

Dimensions

Part No.	Hand of rotation		Thread d1xP	From SLW linear module
	right	left		
DST-SLW-063001-DS8x10-□	●	●	Ds8x10	SLW-0630 ► Page 1386
DST-SLW-063001-DS8x15-□	●	●	Ds8x15	SLW-0630 ► Page 1386
SWZ-063001	●	–	M8	SLW-0630 ► Page 1386
SWZ-063003	–	●	M8	SLW-0630 ► Page 1386
SWZ-063009	●	–	Tr8x1.5	SLW-0630 ► Page 1386
SWZ-063010	–	●	Tr8x1.5	SLW-0630 ► Page 1386

Part number suffix LH for left-hand thread, RH for right-hand thread

Lead screw nuts



Order key

Order example

DST-SLW-25120-DS18x24- J -□



Options:
Hand of rotation
RH: Right-Hand
LH: Left-hand

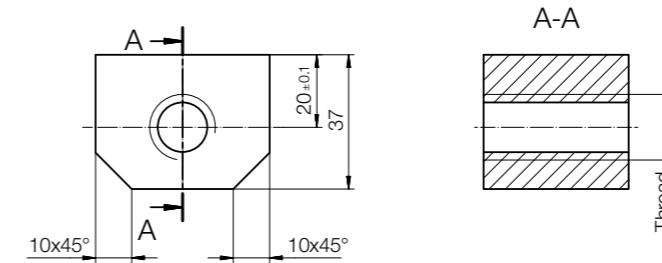

Dimensions

Part No.	Hand of rotation		Thread d1xP	From SLW linear module
	right	left		
DST-SLW-25120-DS18x24-J-□	●	●	Ds18x24	SLW-25120 ► Page 1386
DST-SLW-25120-DS18x40-J-□	●	●	Ds18x40	SLW-25120 ► Page 1386
DST-SLW-25120-DS18x80-J-□	●	●	Ds18x80	SLW-25120 ► Page 1386
DST-SLW-25120-DS18x100-J-□	●	●	Ds18x100	SLW-25120 ► Page 1386

Part number suffix LH for left-hand thread, RH for right-hand thread

Lead screw nuts with locating spigot



DST-SLW-1040 SWZ-W-10XX

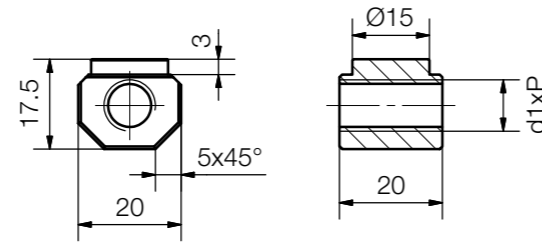

Dimensions

Part No.	Thread d1xP	Hand of rotation	From SLW linear module
DST-SLW-1040-DS10X12-J-RH New	Ds10x12	right-hand	SLW-1040 ► Page 1386
DST-SLW-1040-DS10X12-J-LH New	Ds10x12	left-hand	SLW-1040 ► Page 1386
DST-SLW-1040-DS10X25-J-RH New	Ds10x25	right-hand	SLW-1040 ► Page 1386
DST-SLW-1040-DS10X25-J-LH New	Ds10x25	left-hand	SLW-1040 ► Page 1386
DST-SLW-1040-DS10X50-J-RH New	Ds10x50	right-hand	SLW-1040 ► Page 1386
DST-SLW-1040-DS10X50-J-LH New	Ds10x500	left-hand	SLW-1040 ► Page 1386
SWZ-W-104003	Tr10x2	right-hand	SLW-1040 ► Page 1386
SWZ-W-104004	Tr10x2	left-hand	SLW-1040 ► Page 1386
SWZ-W-104009	TR10x3	right-hand	SLW-1040 ► Page 1386
SWZ-W-104015	Tr10x3	left-hand	SLW-1040 ► Page 1386



SWZ-W-16XX

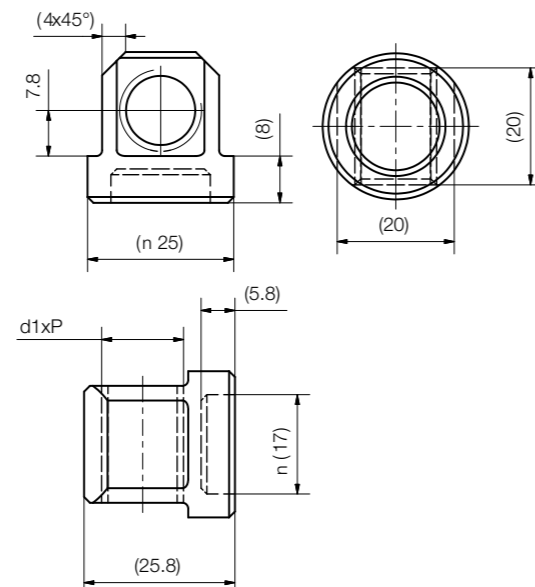

Dimensions

Part No.	Thread d1xP	Hand of rotation	From SLW linear module
SWZ-W-166001	TR14x4	right-hand	SLW-1660 ► Page 1386
SWZ-W-166002	Tr14x3	right-hand	SLW-1660 ► Page 1386
SWZ-W-166003	Tr14x4	left-hand	SLW-1660 ► Page 1386



DST-SLW-2080 SWZ-W-20XX

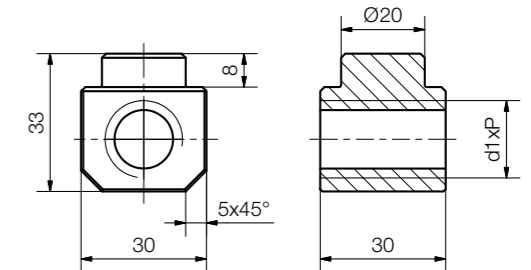

SWZ-W-2080..

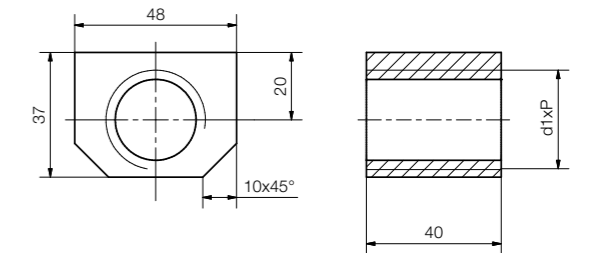

SWZ-W-25120..

Part No.	Thread d1xP	Hand of rotation	From SLW linear module
DST-SLW-2080-DS18X24-J-RH New	Ds18x24	right-hand	SLW-2080 ► Page 1386
DST-SLW-2080-DS18X24-J-LH New	Ds18x24	left-hand	SLW-2080 ► Page 1386
DST-SLW-2080-DS18X40-J-RH New	Ds18x40	right-hand	SLW-2080 ► Page 1386
DST-SLW-2080-DS18X40-J-LH New	Ds18x40	left-hand	SLW-2080 ► Page 1386
DST-SLW-2080-DS18X80-J-RH New	Ds18x80	right-hand	SLW-2080 ► Page 1386
DST-SLW-2080-DS18X80-J-LH New	Ds18x80	left-hand	SLW-2080 ► Page 1386
DST-SLW-2080-DS18X100-J-RH New	Ds18x100	right-hand	SLW-2080 ► Page 1386
DST-SLW-2080-DS18X100-J-LH New	Ds18x100	left-hand	SLW-2080 ► Page 1386
SWZ-W-208003	Tr18x4	right-hand	SLW-2080 ► Page 1386
SWZ-W-208004	Tr18x4	left	SLW-2080 ► Page 1386
SWZ-W-208008	Tr18x8p4	right-hand	SLW-2080 ► Page 1386
SWZ-W-208009	Tr18x8p4	left-hand	SLW-2080 ► Page 1386
SWZ-W-2512001 ¹¹⁹⁾	Tr24x5	right-hand	SLW-25120 ► Page 1386
SWZ-W-2512002 ¹¹⁹⁾	Tr24x5	left-hand	SLW-25120 ► Page 1386

¹¹⁹⁾ Without locating spigot

drylin® | Special geometries | Product range

Angular compensation lead screw nut with spherical ball
in flanged bearing housing



Part number **J F R K M-EFOM-TR 8X1.5** Thread

iglidur® material	Form F	Hand of rotation	Dimensional series K	Metric	Flanged bearing housing	Trapezoidal thread	Diameter [mm]	Pitch
-------------------	--------	------------------	----------------------	--------	-------------------------	--------------------	---------------	-------

Options:
DS: High helix thread
TR: Trapezoidal thread

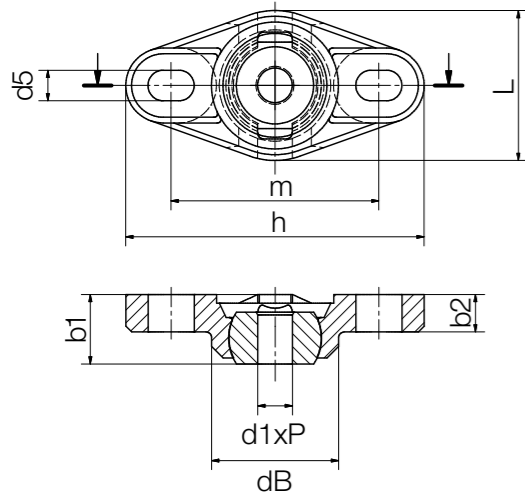

Dimensions [mm] – trapezoidal thread

Thread	Effective support surface [mm²]	d1 ¹⁵⁶⁾	h	L	b1 ¹⁵⁶⁾	b2	m	dB	d5	Max. static axial F [N]	Pivoting angle		Part No.
											stat.	dyn.	
Tr8x1.5	102	8	52	26	12	6.5	36	22.2	5.3x8	100	25°	30°	JFRKM-EFOM-TR8X1.5
Tr10x2	127	10	52	26	12	6.5	36	22.2	5.3x8	100	25°	30°	JFRKM-EFOM-TR10X2
Tr10x3	120	10	52	26	12	6.5	36	22.2	5.3x8	100	25°	30°	JFRKM-EFOM-TR10X3

Dimensions [mm] – high helix thread

Thread	Effective support surface [mm²]	d1 ¹⁵⁶⁾	h	L	b1 ¹⁵⁶⁾	b2	m	dB	d5	Max. static axial F [N]	Pivoting angle		Part No.
											stat.	dyn.	
Ds8x15	61	8	52	26	12	6.5	36	22.2	5.3x8	50	25°	30°	JFRKM-EFOM-DS8X15
Ds10x12	82	10	52	26	12	6.5	36	22.2	5.3x8	50	25°	30°	JFRKM-EFOM-DS10X12

¹⁵⁶⁾ Tolerances according to DIN ISO 2768-1, tolerance class m (medium)

drylin® | Special geometries | Product range

Angular compensation lead screw nut with spherical ball
in pillow block bearing housing

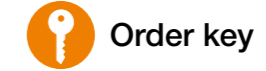

Part number **J F R K M-ESTM-TR 8X1.5** Thread

iglidur® material	Form F	Hand of rotation	Dimensional series K	Metric	Pillow block bearing housing	Trapezoidal thread	Diameter [mm]	Pitch
-------------------	--------	------------------	----------------------	--------	------------------------------	--------------------	---------------	-------

Options:
DS: High helix thread
TR: Trapezoidal thread

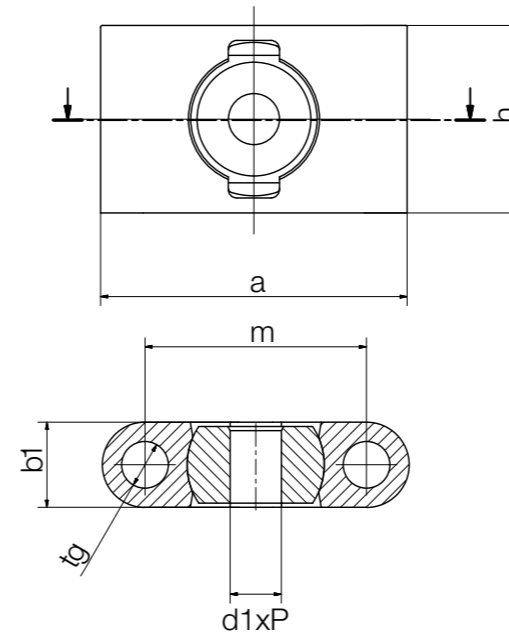

Dimensions [mm] – trapezoidal thread

Thread	Effective support surface [mm²]	h	a	b1 ¹⁵⁶⁾	m	tg	Max. static axial F [N]	Pivoting angle		Part No.
								stat.	dyn.	
Tr8x1.5	102	22	36	10	26	5.5	100	25°	30°	JFRKM-ESTM-TR8X1.5
Tr10x2	127	22	36	10	26	5.5	100	25°	30°	JFRKM-ESTM-TR10X2
Tr10x3	120	22	36	10	26	5.5	100	25°	30°	JFRKM-ESTM-TR10X3

Dimensions [mm] – high helix thread

Thread	Effective support surface [mm²]	h	a	b1 ¹⁵⁶⁾	m	tg	Max. static axial F [N]	Pivoting angle		Part No.
								stat.	dyn.	
Ds8x15	61	22	36	10	26	5.5	50	25°	30°	JFRKM-ESTM-DS8X15
Ds10x12	82	22	36	10	26	5.5	50	25°	30°	JFRKM-ESTM-DS10X12

¹⁵⁶⁾ Tolerances according to DIN ISO 2768-1, tolerance class m (medium)



Part number Thread

F T R M- FF - 10X2

Form F	Trapezoidal thread	Hand of rotation	Metric	Fast Forward	Diameter	Pitch
--------	--------------------	------------------	--------	--------------	----------	-------

Quick release mechanism: A combination of accurate positioning and fast manual adjustment with trapezoidal lead screw nuts.

- For quick format adjustments
- Incl. 'stop/go' through automatic self-locking with thread
- Housing: AL anodised, lead screw nut made from iglidur® J
- Tough and reliable
- Only recommended for horizontal applications
- Max. axial load stat.: 200N, dyn.: 50N
see SHT-FF ► Page 1380

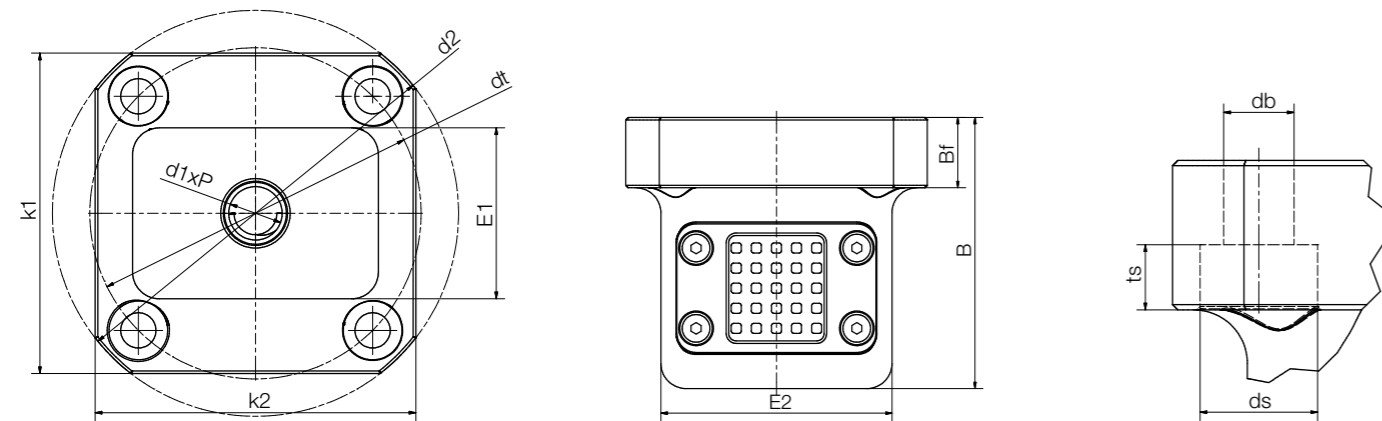

Dimensions [mm]

Thread	d2 ¹⁵⁶⁾	dt	B	Bf	ts	db	ds	k1	k2	E1	E2	Part No.
Tr10x2	76	62	54	14	6.1	6.6	11	60	60	32	46	FTRM-FF-10X2

¹⁵⁶⁾ Tolerances according to DIN ISO 2768-1, tolerance class m (medium)



Type d3 b1 Thread

J D R M- 42 09 TR 10X2

iglidur® material	Form: disc	Hand of rotation	Metric	Outer Ø [mm]	Height [mm]	Trapezoidal thread	Diameter	Pitch
-------------------	------------	------------------	--------	--------------	-------------	--------------------	----------	-------

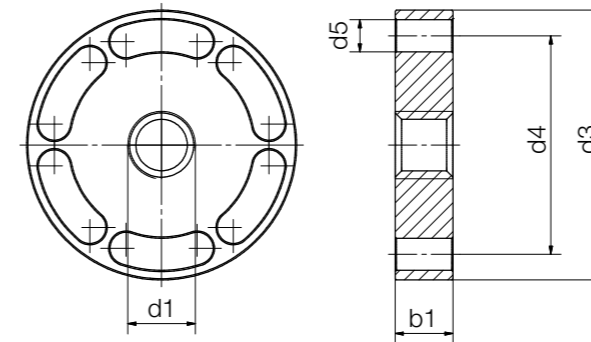

Material properties:
iglidur® J ► Page 159

Technical data and dimensions [mm]

Thread	Effective supporting surface [mm ²]	Max. stat. axial F ⁴⁹⁾ [N]	d1 ¹⁵⁶⁾	d3	d4	d5	b1 ¹⁵⁶⁾	Weight [g]	Part No.
Tr10x2	127	508	10	42	34	5	9	17.5	JDRM-4209TR10X2
Tr12x3	181	724	12	48	38	6	11	27.8	JDRM-4811TR12X3
Tr14x4	207	828	14	48	38	6	11	27.1	JDRM-4811TR14X4
Tr16x4	241	964	16	48	38	6	11	26.4	JDRM-4811TR16X4
Tr18x4	276	1,104	18	48	38	6	11	25.5	JDRM-4811TR18X4
Tr20x4	367	1,468	20	55	45	7	13	39.9	JDRM-5513TR20X4
Tr24x5	439	1,756	24	55	45	7	13	37.3	JDRM-5513TR24X5
Tr30x6	551	2,204	30	62	50	7	14	48.2	JDRM-6214TR30X6
Tr36x6	829	3,316	36	70	58	7	16	67.5	JDRM-7016TR36X6

⁴⁹⁾ Max. stat. F axial can be added when used with flange nut

¹⁵⁶⁾ Tolerances according to DIN ISO 2768-1, tolerance class m (medium)



Order key

Part number

MH-1210-AL-TR10X2-R-J

Lead screw nut housings	Nut design (see drawing)	Aluminium	Thread size	Right-hand thread	iglidur® J nut
-------------------------	-----------------------------	-----------	-------------	-------------------	----------------

- Standard lead screw nuts secured with fixing screws
- Can be fixed from above
- One housing is suitable for many thread geometries
- Limitless combinations

MHM-2835-AL-□ / MHM-3244-AL-□



MHM-ZB0810-AL-□



MHM-2018-AL-□



MHM-1210-AL-□



i Please use MHM (Assembled lead screw nut housing, including lead screw nut) for fully assembled systems. Order example: MHM-1210-AL-TR10x2-R-J

MH-1210-AL

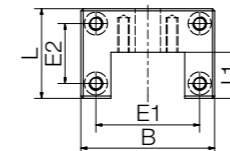
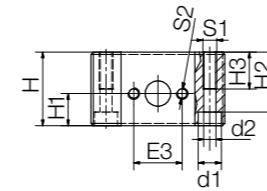

MH-2018-AL

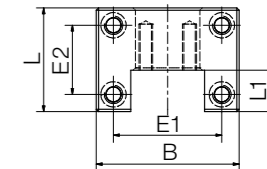
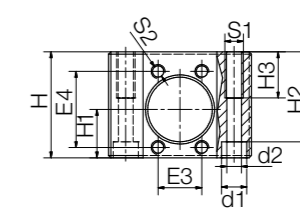

MH-2835-AL

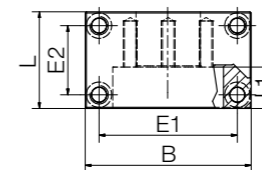
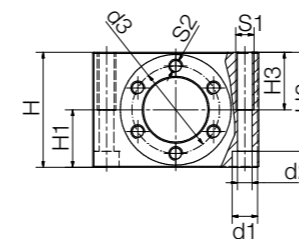

MH-3244-AL

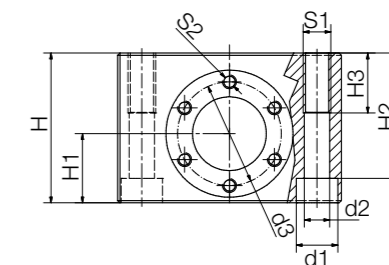

MH-ZB0810-AL

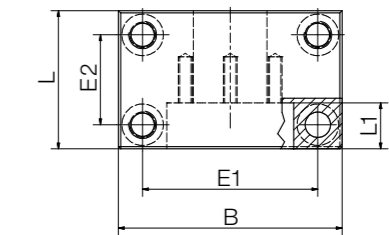
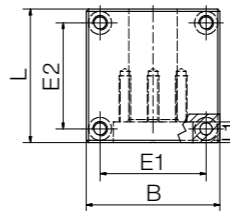
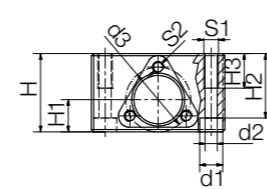

Dimensions [mm]

Part No.	H	H1	H2	H3	S1	S2	B	L	L1	E1	E2	E3	E4	d1	d2	d3	Can be combined with SLS
							±0.3	±0.3		±0.15	±0.15						
MH-1210-AL	32	14	26	16	M6	M5	58	39	20	45	26	21	-	10	5.3	-	●
MH-2018-AL	46	21	39	20	M8	M6	62	45	18	47	30	19	33	11	6.4	-	●
MH-2835-AL	50	25	43	25	M8	M6	72	42	18	60	30	-	-	11	6.4	38	-
MH-3244-AL	65	30	54.4	26	M12	M6	97	60	20	76	39	-	-	18	11	45	●
MH-ZB0810-AL	34	14	28	15	M6	M5	58	34	9	46	46	-	-	10	5.3	28.2	●

Part No.	Nut design	Thread size
MH-1210-AL	SHT-1210-TRM	Tr10x2 / Tr10x3 / Ds10x12 / Ds10x50
MH-2018-AL	SHT-2018-TRM	Tr18x4 / Tr18x8P4 / Ds18x24 / Ds18x100
MH-2835-AL	FRM-2835	Tr12x3 / Tr12x6P3 / Ds12x25 / Tr14x3 / Tr14x4 / Tr16x2 / Tr16x4 / Tr16x8P4 / Tr18x4 / Tr18x8P4 / Ds18x24 / Ds18x100
MH-3244-AL	FRM-3244	Tr20x4 / Tr20x8P4 / Tr24x5
MH-ZB0810-AL	Zero-backlash	Ds08x10 / Ds08x15 / Ds10x12 / Ds10x50



Order key

Part No.	Thread	Options
----------	--------	---------

SLS - 10X2 - FL - LH

Lead screw support block	Diameter	Pitch	Fixed bearing	Option left-hand thread
--------------------------	----------	-------	---------------	-------------------------

Options:

- FL: Fixed bearing
- LL: Floating bearing
- LH: Left-hand thread option only for Tr10x2, Tr10x3, Tr18x4, Tr24x5



Scope of delivery: Anodised lead screw support block

FL: Fixed bearing with anodised clamping ring with RH thread (standard) and maintenance-free iglidur® plain bearing⁵²⁾

LL: Floating bearing with maintenance-free iglidur® plain bearing

Technical data and dimensions [mm] – (for both right and left-hand threads)

Part No.	Weight [g]	Max. static load capacity axial [N]	S1	S2	S3
SLS-10X2-FL (LH)	88	700	M8	-	-
SLS-10X2-LL	115	-	M8	M4	M6
SLS-10X3-FL (LH)	88	700	M8	-	-
SLS-10X3-LL	115	-	M8	M4	M6
SLS-10X12-FL	88	700 ⁵³⁾	M8	-	-
SLS-10X12-LL	115	-	M8	M4	M6
SLS-10X50-FL	88	700 ⁵³⁾	M8	-	-
SLS-10X50-LL	115	-	M8	M4	M6
SLS-12X3-FL New	205	1,600	M12	-	-
SLS-12X3-LL New	295	-	M12	M4	M6
SLS-14X3-FL New	205	1,600	M12	-	-
SLS-14X3-LL New	295	-	M12	M4	M6
SLS-14X4-FL New	205	1,600	M12	-	-
SLS-14X4-LL New	295	-	M12	M4	M6
SLS-16X2-FL New	205	1,600	M12	-	-
SLS-16X2-LL New	295	-	M12	M4	M6
SLS-16X4-FL New	205	1,600	M12	-	-
SLS-16X4-LL New	295	-	M12	M4	M6

⁵²⁾ FL lead screw support block with trapezoidal thread TR10x2, TR10x3, TR18x4, TR24x5 lead screw also available with clamping rings with left-hand thread

⁵³⁾ Can exceed max. stat. load of the nut

⁵⁴⁾ Lead screw end must be turned to d1 value

⁵⁵⁾ Lead screw end must be turned to 18mm

Fixed bearing

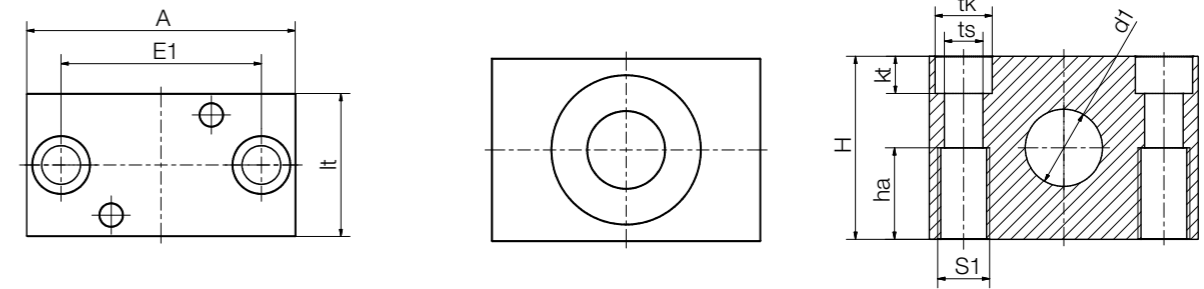

Floating bearing

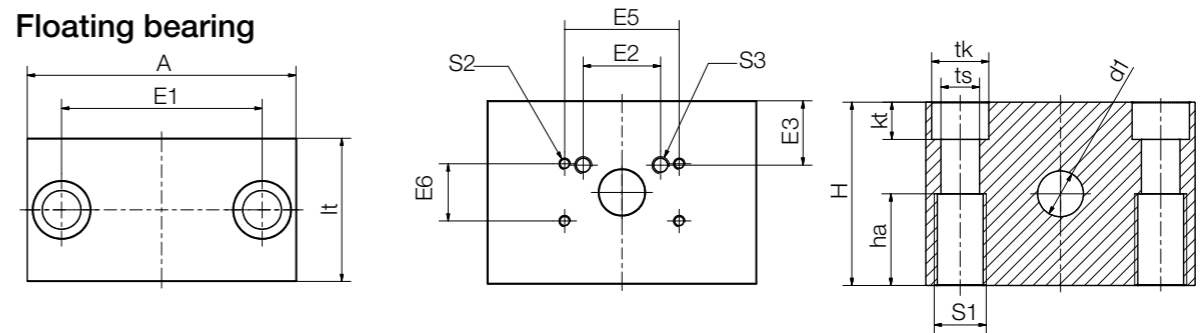

► Page 1447

Dimensions [mm] – (for both right and left-hand threads)

A	H	E1	E2	E3	E5	E6	lt	kt	tk	ts	d1	ha
50	32	36	-	-	-	-	30	6.5	11	6.6	10	16
50	32	36	27	6.5	40	20	30	6.5	11	6.6	10	16
50	32	36	-	-	-	-	30	6.5	11	6.6	10	16
50	32	36	27	6.5	40	20	30	6.5	11	6.6	10	16
50	32	36	-	-	-	-	30	6.5	11	6.6	10	16
50	32	36	27	6.5	40	20	30	6.5	11	6.6	10	16
50	32	36	-	-	-	-	30	6.5	11	6.6	10	16
50	32	36	27	6.5	40	20	30	6.5	11	6.6	10	16
72	46	54	-	-	-	-	36	8.6	15	9	12	23
72	46	54	27	13.5	40	20	36	8.6	15	9	12	23
72	46	54	-	-	-	-	36	8.6	15	9	14	23
72	46	54	27	13.5	40	20	36	8.6	15	9	14	23
72	46	54	-	-	-	-	36	8.6	15	9	14	23
72	46	54	27	13.5	40	20	36	8.6	15	9	14	23
72	46	54	-	-	-	-	36	8.6	15	9	16	23
72	46	54	27	13.5	40	20	36	8.6	15	9	12	23
72	46	54	-	-	-	-	36	8.6	15	9	16	23
72	46	54	27	13.5	40	20	36	8.6	15	9	12	23

Technical data and dimensions [mm] – (for both right and left-hand threads)

Part No.	Weight [g]	Max. static load capacity axial [N]	S1	S2	S3
SLS-18X4-FL (LH)	205	1,600	M12	–	–
SLS-18X4-LL ⁵⁴⁾	295	–	M12	M4	M6
SLS-18X8P4-FL	205	1,600	M10	–	–
SLS-18X8P4-LL ⁵⁴⁾	295	–	M10	M4	M6
SLS-18X24-FL ⁵⁵⁾	205	1,600 ⁵³⁾	M10	–	–
SLS-18X24-LL ⁵⁴⁾	295	–	M10	M4	M6
SLS-18X100-FL ⁵⁵⁾	205	1,600 ⁵³⁾	M10	–	–
SLS-18X100-LL ⁵⁴⁾	295	–	M10	M4	M6
SLS-20X4-FL New	525	2,500	M16	–	–
SLS-20X4-LL New	725	–	M16	M4	M6
SLS-24X5-FL (LH)	525	2,500	M16	–	–
SLS-24X5-LL ⁵⁴⁾	725	–	M16	M4	M6
Lead screw support blocks with plain bearings (clamping rings without thread)					
SLS-S6-FL New	115	–	M8	–	–
SLS-S6-LL New	88	150	M8	M4	M6
SLS-S6.35-FL New	115	–	M8	–	–
SLS-S6.35-LL New	88	150	M8	M4	M6
SLS-S8-FL New	115	–	M8	–	–
SLS-S8-LL New	88	500	M8	M4	M6
SLS-S10-FL New	88	700	M8	–	–
SLS-S10-LL New	115	–	M8	M4	M6
SLS-S12-FL New	205	1,600	M12	–	–
SLS-S12-LL New	295	–	M12	M4	M6
SLS-S14-FL New	205	1,600	M12	–	–
SLS-S14-LL New	295	–	M12	M4	M6
SLS-S16-FL New	205	1,600	M12	–	–
SLS-S16-LL New	295	–	M12	M4	M6
SLS-S18-FL New	205	1,600	M12	–	–
SLS-S18-LL New	295	–	M12	M4	M6
SLS-S20-FL New	525	2,500	M16	–	–
SLS-S20-LL New	725	–	M16	M4	M6

⁵³⁾ Can exceed max. stat. load of the nut

⁵⁴⁾ Lead screw end must be turned to d1 value

⁵⁵⁾ Lead screw end must be turned to 18mm

A	H	E1	E2	E3	E5	E6	lt	kt	tk	ts	d1	ha
72	46	54	–	–	–	–	36	8.6	15	9.0	18	23
72	46	54	27	13.5	40	20	36	8.6	15	9.0	12	23
72	46	54	–	–	–	–	36	8.6	15	9.0	18	23
72	46	54	27	13.5	40	20	36	8.6	15	9.0	12	23
72	46	54	–	–	–	–	36	8.6	15	9.0	18	23
72	46	54	27	13.5	40	20	36	8.6	15	9.0	12	23
72	46	54	–	–	–	–	36	8.6	15	9.0	18	23
72	46	54	27	13.5	40	20	36	8.6	15	9.0	12	23
94	64	70	–	–	–	–	50	13	20	13.5	12	32
94	64	70	27	22.5	40	20	50	13	20	13.5	20	32
94	64	70	–	–	–	–	50	13	20	13.5	24	32
94	64	70	27	22.5	40	20	50	13	20	13.5	14	32
Lead screw support blocks with plain bearings (clamping rings without thread)												
50	32	36	–	–	–	–	30	6.5	11	6.6	6	16
50	32	36	27	6.5	40	20	30	6.5	11	6.6	6	16
50	32	36	–	–	–	–	30	6.5	11	6.6	6.35	16
50	32	36	27	6.5	40	20	30	6.5	11	6.6	6.35	16
50	32	36	–	–	–	–	30	6.5	11	6.6	8	16
50	32	36	27	6.5	40	20	30	6.5	11	6.6	8	16
50	32	36	–	–	–	–	30	6.5	11	6.6	10	16
50	32	36	27	6.5	40	20	30	6.5	11	6.6	10	16
72	46	54	–	–	–	–	36	8.6	15	9.0	12	23
72	46	54	27	13.5	40	20	36	8.6	15	9.0	12	23
72	46	54	–	–	–	–	36	8.6	15	9.0	14	23
72	46	54	27	13.5	40	20	36	8.6	15	9.0	14	23
72	46	54	–	–	–	–	36	8.6	15	9.0	12	23
72	46	54	27	13.5	40	20	36	8.6	15	9.0	16	23
72	46	54	–	–	–	–	36	8.6	15	9.0	12	23
72	46	54	27	13.5	40	20	36	8.6	15	9.0	18	23
94	64	70	–	–	–	–	50	13.0	20	13.5	12	32
94	64	70	27	22.5	40	20	50	13.0	20	13.5	20	32



Order key

Part No.	Thread	Options
----------	--------	---------

SLS - 10X2 - BB

Lead screw support block

Diameter

Pitch

Ball bearing

Options:
BB: Ball bearings
FL: Fixed bearing
LL: Floating bearing



► Page 1447

Fixed bearing

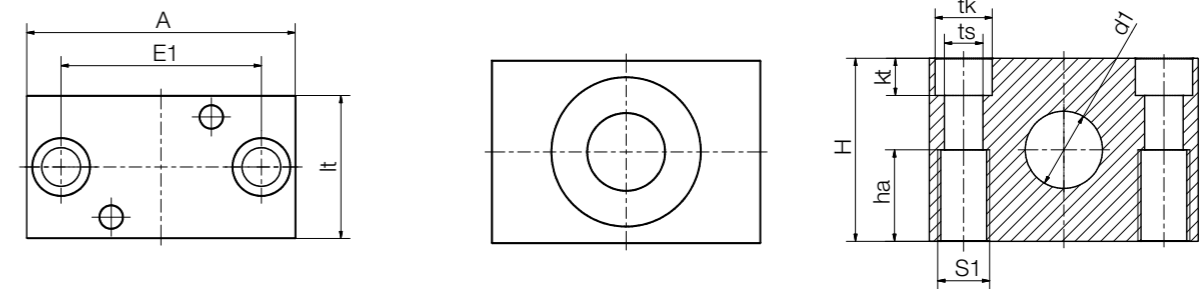

Floating bearing

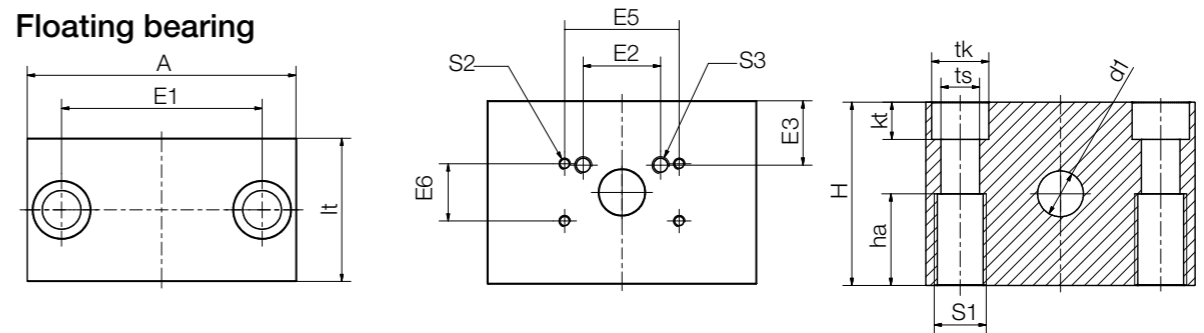

Technical data and dimensions, ball bearing [mm]

Part No.	Weight [g]	Max. stat. load capacity axial [N]	S1	S2	
SLS-S6-BB	New	110	150	M8	M4
SLS-S6.35-BB	New	110	150	M8	M4
SLS-S8-BB	New	110	350	M8	M4
SLS-S10-BB	New	110	350	M8	M4
SLS-S12-BB	New	265	1,000	M12	M4
SLS-S14-BB	New	265	1,000	M12	M4
SLS-S16-BB	New	265	1,000	M12	M4
SLS-S18-BB	New	265	1,000	M12	M4
SLS-S20-BB	New	350	1,500	M16	M4
SLS-10X2-BB		110	350	M8	M4
SLS-10X3-BB	New	110	350	M8	M4
SLS-10X12-BB		110	350	M8	M4
SLS-10X50-BB		110	350	M8	M4
SLS-12X3-BB	New	265	1,000	M12	M4
SLS-14X4-BB	New	265	1,000	M12	M4
SLS-16X2-BB	New	265	1,000	M12	M4
SLS-16X4-BB	New	265	1,000	M12	M4
SLS-18X4-BB	New	265	1,000	M12	M4
SLS-18X8P4-BB		265	1,000	M10	M4
SLS-18X24-BB ⁵⁵⁾		265	1,000	M10	M4
SLS-18X100-BB ⁵⁵⁾		265	1,000	M10	M4
SLS-20X4-BB	New	350	1,500	M16	M4
SLS-24X5-BB		350	1,500	M16	M4

⁵⁵⁾ Lead screw end must be turned to 18mm

Dimensions, ball bearing [mm]

A	H	E1	E5	E6	lt	kt	tk	ts	d1	ha
50	32	36	40	20	30	6.5	11	6.6	6	16
50	32	36	40	20	30	6.5	11	6.6	6.35	16
50	32	36	40	20	30	6.5	11	6.6	8	16
50	32	36	40	20	30	6.5	11	6.6	10	16
72	46	54	48	36	36	8.6	15	9.0	12	23
72	46	54	48	36	36	8.6	15	9.0	14	23
72	46	54	48	36	36	8.6	15	9.0	16	23
72	46	54	48	36	36	8.6	15	9.0	18	23
94	64	70	48	36	50	13.0	20	13.5	20	32
50	32	36	40	20	30	6.5	11	6.6	10	16
50	32	36	40	20	30	6.5	11	6.6	10	16
50	32	36	40	20	30	6.5	11	6.6	10	16
72	46	54	48	36	36	8.6	15	9.0	12	23
72	46	54	48	36	36	8.6	15	9.0	14	23
72	46	54	48	36	36	8.6	15	9.0	16	23
72	46	54	48	36	36	8.6	15	9.0	18	23
72	46	54	48	36	36	8.6	15	9.0	18	23
72	46	54	48	36	36	8.6	15	9.0	18	23
72	46	54	48	36	36	8.6	15	9.0	18	23
94	64	70	48	36	50	13.0	20	13.5	20	32
94	64	70	48	36	50	13.0	20	13.5	24	32

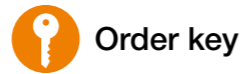

Order key

Part number Thread

CR R-01-TR 10X2

Clamping rings	Hand of rotation	Type	Trapezoidal thread	Diameter	Pitch
----------------	------------------	------	--------------------	----------	-------

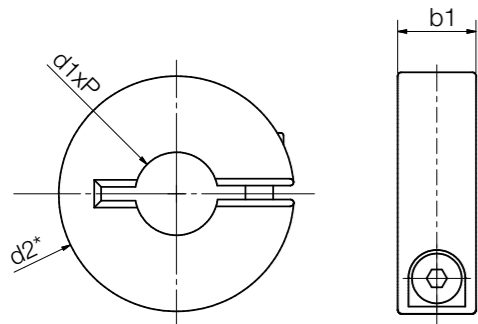

Dimensions [mm]

Thread	d2 ⁵⁶⁾ h9	b1	Max. static axial F [N]	Part No. Right-hand thread
Tr8x1.5	16	9	1,530	CRR-01-TR8X1.5
Tr10x2	24	8	1,800	CRR-01-TR10X2
Tr12x3	28	8	2,096	CRR-01-TR12X3
Tr14x4	30	11	3,312	CRR-01-TR14X4
Tr16x4	34	11	3,840	CRR-01-TR16X4
Tr18x4	36	13	5,216	CRR-01-TR18X4
Tr20x4	45	15	6,784	CRR-01-TR20X4
Tr24x5	45	15	8,096	CRR-01-TR24X5

Thread	d2 ⁵⁶⁾ h9	b1	Max. static axial F [N]	Part No. Left-hand thread
Tr8x1.5	16	9	1,530	CRL-01-TR8X1.5
Tr10x2	24	8	1,800	CRL-01-TR10X2
Tr12x3	28	8	2,096	CRL-01-TR12X3
Tr14x4	30	11	3,312	CRL-01-TR14X4
Tr16x4	34	11	3,840	CRL-01-TR16X4
Tr18x4	36	13	5,216	CRL-01-TR18X4
Tr20x4	45	15	6,784	CRL-01-TR20X4
Tr24x5	45	15	8,096	CRL-01-TR24X5

⁵⁶⁾ Outside dimension clamping ring. Screw head may protrude. Installation dimension d2 (+2mm)

Dimensions [mm] – clamping ring without thread

ø	d2	b1	Part No.
10	24	8	KRM-S10-V
12	28	11	KRM-S12-V
14	30	11	KRM-S14-V
16	34	11	KRM-S16-V
18	36	13	KRM-S18-V
24	45	15	KRM-S24-V

